

HIGH-PERFORMANCE  
INTERNAL GEAR PUMPS

PRODUCT INFORMATION

COMPREHENSIVE SOLUTIONS  
FROM ONE SOURCE

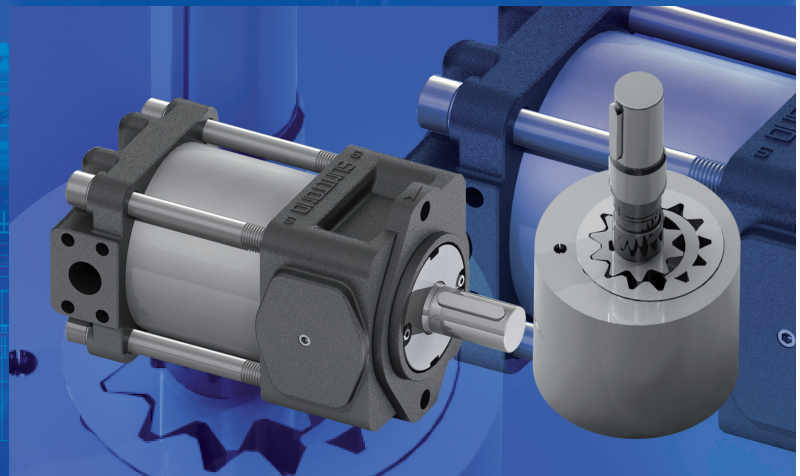

**SAUER BIBUS GmbH**  
DE-89231 Neu-Ulm

**SAUER BIBUS**  
/// **SUPPORTING YOUR SUCCESS**



Registered office of SAUER BIBUS in Neu-Ulm, Germany

## Table Of Contents



<b>Product description</b>	<b>p. 4</b>
Structure and function	
<b>Technical specifications</b>	<b>p. 6</b>
Model overview   Pressure ranges   Manufactured sizes Model descriptions   Accessories	
<b>Characteristics</b>	<b>p. 9</b>
Noise level   Volumetric efficiency Overall efficiency	
<b>Single pumps</b>	<b>p. 13</b>
Low pressure pumps   Medium pressure pumps High pressure pumps   Extreme pressure pumps Performance information   Dimensions   Accessories Sectional drawings	
<b>Double pumps</b>	<b>p. 23</b>
Product overview   Dimensions	
<b>Operation hints</b>	<b>p. 27</b>



## HIGH-PERFORMANCE INTERNAL GEAR PUMPS

### **Precise, low-noise and tailor-made.**

With the high-performance internal gear pump manufactured by the Japanese company Sumitomo, SAUER BIBUS offers exclusive Europe-wide solutions for all pressure ranges. Developed to match the Sumitomo internal gear pump, SAUER BIBUS produces and manufactures customised application-specific complete solutions – to meet the requirement profile.

### **QX line – the new generation.**

The QT line with a long-term world-wide proven track record was improved with structural alterations. The QX line is the new generation of the Sumitomo high-performance internal gear pumps and is characterised by the following properties:

- suitable for use with high pressures
- low noise levels
- high capacity
- low pulsation
- high durability

### **SAUER BIBUS – your qualified contact.**

SAUER BIBUS represents qualified, quick and customised solutions at marketable prices. The 18 branch offices of BIBUS HOLDING AG in Europe provide personal advice on site.

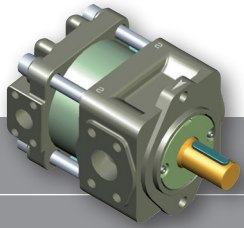

**New QX line.**

The QT line with a long-term world-wide proven track record was improved once again with structural alterations. A specially designed gearing geometry reduces the noise level and allows the quiet operation even with high pressures and rotational speeds. This further development is now available in the new QX line for use in low to extreme pressure ranges.

**Optimisation thanks to new teeth shape.**

In contrast to the previously used involute gearing, the Truning teeth shape used in the QX line results in almost no change in the inclusion volume at all. As a result, the sealing surface is increased and excellent efficiency achieved.

# QX Line – The New Generation

FORMER: INVOLUTE GEAR SHAPE

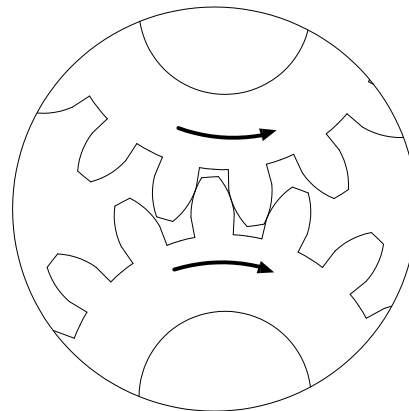

NEW: TRUNINGER TEETH SHAPE OF QX PUMPS

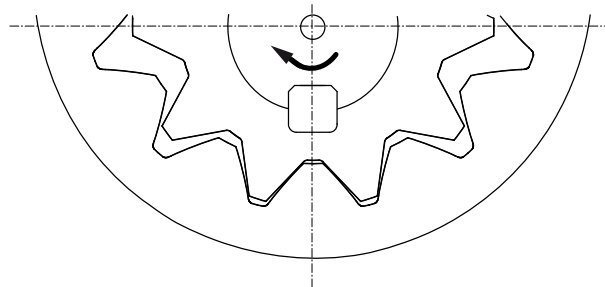

ALTERATION OF THE INCLUSION VOLUME

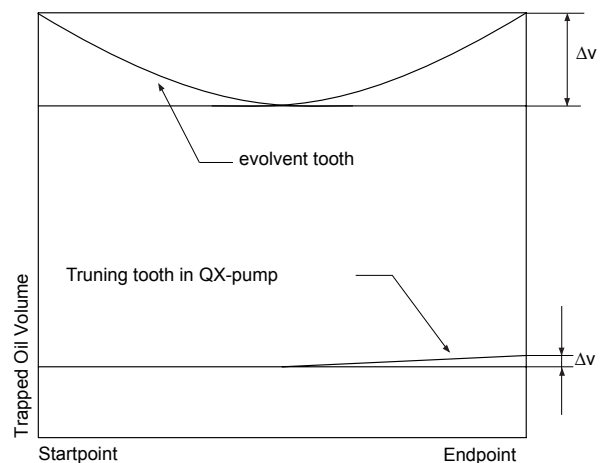

In contrast to the involute gear shape, there is almost no change in the inclusion volume at all with the Truning gearing geometry.

PRESSURE RANGES

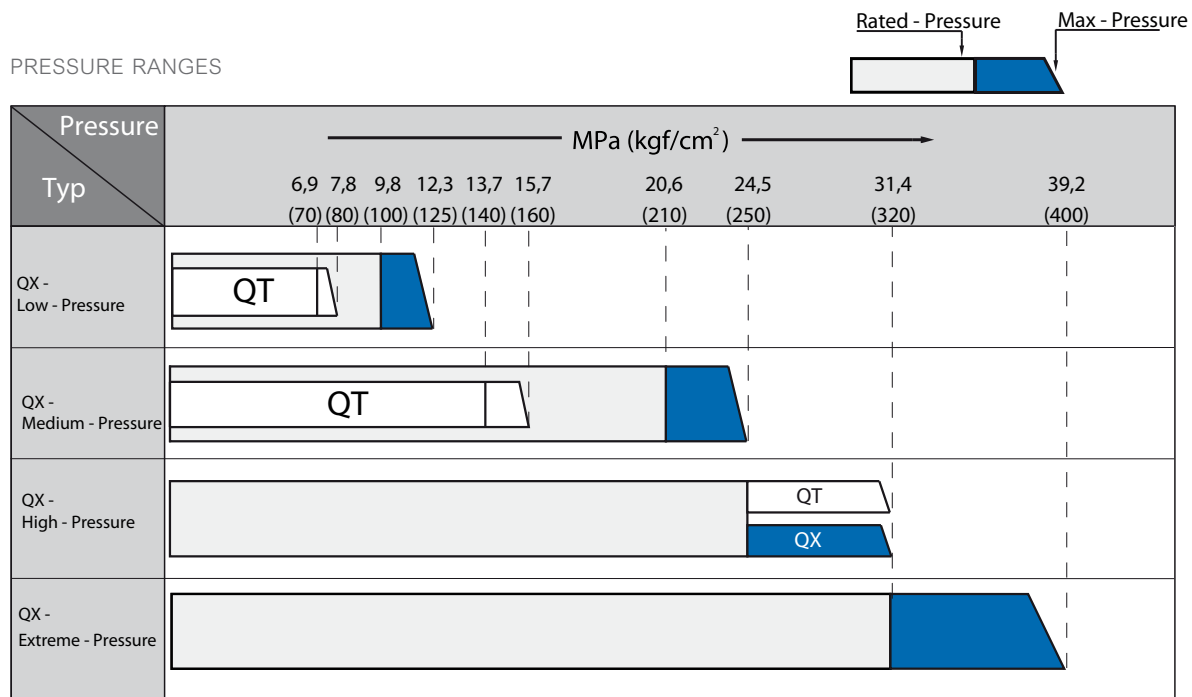

The illustration shows the comparison of the improved QX pump with the current QT pump in the various pressure ranges. The four different pressure types of the QX line offer a broad range of application.

HYDRODYNAMIC AND HYDROSTATIC ARRANGEMENT OF BEARINGS

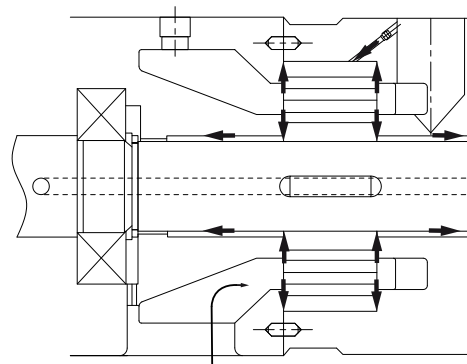

MAX 11.0 MPa

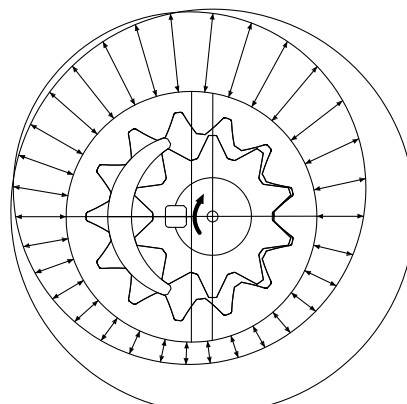

MIN 1.6 MPa

**Improved volumetric efficiency.**

The increase of the sealing surfaces associated with the changed gearing geometry improves the volumetric efficiency by 20%.

**Low pulsation.**

The construction characteristics of the Truning teeth shape achieve a very low pulsation of less than 0.2 MPa. Consequently, the QX line is especially suitable for uses in pulsation-sensitive systems such as plastic machinery, elevators or machine tools.

**High durability.**

The hydrodynamic and hydrostatic arrangement of bearings (compulsory lubrication) in the new construction of the QX line allows smooth operation with lower viscosity of the medium and low rotational speeds. The result: improved durability of components.

Smooth operation and improved durability thanks to compulsory lubrication of the hydrodynamic and hydrostatic arrangement of bearings.

# Technical Specifications

## MODEL OVERVIEW: QX LINE

### LOW PRESSURE PUMP

Model no.		Rated pressure MPa	Maximum pressure MPa	Capacity (l/min at rated pressure)				Driving power (kW) (at rated pressure, 1800 1/min)	Minimum/maximum rotational speed (1/min)
				Rotational speed (1/min)					
				1000	1200	1500	1800		
QX31	-20	9.8 (100)	12.3 (125)	17	21	27	33	6.9	1000-1800
	-25			22	27	35	42	8.6	
	-31.5			28	34	44	53	10.6	
QX41	-40			35	44	56	68	13.7	
	-50			45	55	70	85	16.8	
	-63			60	72	92	111	21.5	
QX51	-80			70	86	109	133	25.9	
	-100			93	113	143	174	33.1	
	-125			119	144	182	220	41.3	
QX61	-160			144	176	224	272	51.8	
	-200			185	226	286	347	64.7	
	-250			233	283	357	432	79.4	

### MEDIUM PRESSURE PUMP

Model no.		Rated pressure MPa		Maximum pressure MPa	Capacity (l/min at rated pressure)				Driving power (kW) (at rated pressure, 1800 1/min)	Minimum/maximum rotational speed (1/min)
		Rot. speed (1/min)			Rotational speed (1/min)					
					1000	1200	1500	1800		
QX22	-4	1500	9.8 (100)	13.7 (140)			5	6		1500-1800
		1800	12.7 (130)	17.7 (180)						
QX22	-6.3	1000	7.8 (80)	9.8 (100)			6	8	1.9	1000-1800
		1200	9.8 (100)	12.7 (130)			8	10	3.8	
		1500	20.6 (210)	24.5 (250)			10	13	4.6	
		1800	20.6 (210)	24.5 (250)						
QX32	-10	20.6 (210)	24.5 (250)	7	9	12	15	5.7	1000-1800	
				-12.5	10	12	16	20		6.8
				-16	13	16	21	26		8.5
QX42	-20			15	20	26	32	10.5		
				-25	20	25	33	41		13.6
				-31.5	27	34	44	54		16.8
QX52	-40			32	40	52	64	21.5		
				-50	43	53	69	85		26.0
				-63	56	67	88	108		33.4
QX62	-80			66	82	107	132	41.8		
				-100	87	107	138	170		52.5
				-125	110	136	174	212		65.9

MODEL OVERVIEW: QX LINE

HIGH PRESSURE PUMP

Model no.		Rated pressure		Maximum pressure MPa	Capacity (l/min at rated pressure)				Driving power (kW) (at rated pressure, 1800 1/min)	Minimum/maximum rotational speed (1/min)
		Rot. speed (1/min)	MPa		Rotational speed (1/min)					
					1000	1200	1500	1800		
QX23	-4	1500	15.7 (160)	21.6 (220)			5	6	3.1	1000–1800
		1800	20.6 (210)							
QX23	-5	1000	11.8 (120)	16.7 (170)			6	8	4.6	
		1200	14.7 (150)							
	-6.3	1500	24.5 (250)	31.4 (320)			8	10	5.5	
		1800	24.5 (250)							
QX33	-10	24.5 (250)	31.4 (320)	8	10	13	16	8.3		
				10	13	17	21	10.4		
				13	16	21	26	12.8		
QX43	-20	24.5 (250)	31.4 (320)	17	22	28	34	13.6		
				22	27	35	43	20.4		
				29	36	46	56	26.2		
QX53	-40	24.5 (250)	31.4 (320)	34	42	55	67	31.6		
				46	56	72	87	40.6		
				59	72	91	110	50.8		
QX63	-80	24.5 (250)	31.4 (320)	70	87	111	136	63.9		
				91	112	142	173	80.1		
				115	140	178	216	98.6		

EXTREME PRESSURE PUMP

Model no.		Rated pressure MPa	Maximum pressure MPa	Capacity (l/min at rated pressure)				Driving power (kW) (at rated pressure, 1800 1/min)	Minimum/maximum rotational speed (1/min)			
				Rotational speed (1/min)								
				1000	1200	1500	1800					
QX2H	-5	31.4 (320)	39.2 (400)			6	8	5.8				
									-6.3	7	10	7.0
QX3H	-10	31.4 (320)	39.2 (400)	7	9	12	15	10.4				
				-12.5	9	12	16	20	13.1			
					-16	12	16	20	25	16.2		
QX4H	-20	31.4 (320)	39.2 (400)	16	21	27	33	20.9				
				-25	21	26	34	42	25.8			
					-31.5	28	35	45	55	33.1		
QX5H	-40	31.4 (320)	39.2 (400)	33	41	53	65	40.0				
				-50	44	55	70	86	51.3			
					-63	57	70	90	109	64.3		
QX6H	-80	31.4 (320)	39.2 (400)	67	84	109	134	80.7				
				-100	88	109	140	171	101			
					-125	112	137	176	214	125		

Note 1: This table is an overview of available pumps and the respective pressure ranges. Please refer to the pump performance table for precise values of the respective pump.

Note 2: High pressure pump designs with a counter-clockwise sense of rotation are only manufactured by request. Please contact your local BIBUS representative for advice.

Note 3: The following application conditions apply to maximum pressure: duration less than 1/3 of a cycle, max. duration: 20 seconds.

## TECHNICAL SPECIFICATIONS |

### MODEL DESCRIPTIONS

QX	XX	XX	XX	XX	XX	S	A
Basic model	Manufactured size	Pressure range	Theoretical capacity	Sense of rotation	Options	Specifications	Draft no.
Gear pump for high pressures at low noise levels	2 3 4 5 6	1: low pressure 2: medium pressure 3: high pressure H: extreme pressure	See pump overview table	Without symbol: clockwise  L: counter-clockwise	<b>Suction pressure:</b>  Without symbol: -0.03 to 0.03 MPa (standard)  H: 0 bis 0.2 MPa (high pressure lip seal)  <b>Sealing material:</b>  Without symbol: NBR  V: use of Viton seals for phosphoric ester  W: water-glycol base (change in the pump only)	Entry in case of special specifications only	00: without symbol  0X: compatible  X: not compatible

Note 1: Models of the QX8x line are only manufactured by request. Please contact your local BIBUS representative for advice.

Note 2: High pressure and extreme pressure pumps with a counter-clockwise sense of rotation are only manufactured by request. Please contact your local BIBUS representative for advice.

### INSTALLATION FLANGE

QG	XX	XX
Basic model	Installation type	Size
Flange	T: screwed connection	04–28
	W: welded joint	
	F: screwed connection	04–10

### PUMP BASE

QF	XX	XX
Basic model	Size	Options
Base design	Same as pump size	Without symbol: singel pump D: double pump

### SINGLE PUMPS: ORDER EXAMPLES

EXAMPLE 1

**QG T-04**

Flange

Screws

Manufactured size "4"

EXAMPLE 2

**QX-4 3-25 LH-A**

Model

Manufactured size "4"

High pressure

Theor. volume 25 cm<sup>3</sup>/rev

Series

High pressure lip seal

Counter-clockwise sense of rotation



# Characteristic Curves

## LOW PRESSURE PUMPS: CHARACTERISTIC CURVES

NOISE LEVEL

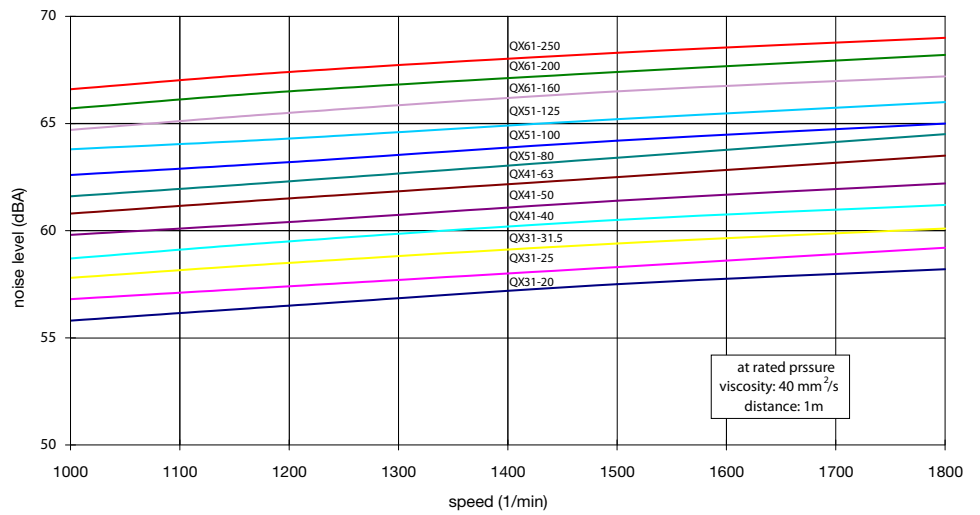

VOLUMETRIC EFFICIENCY

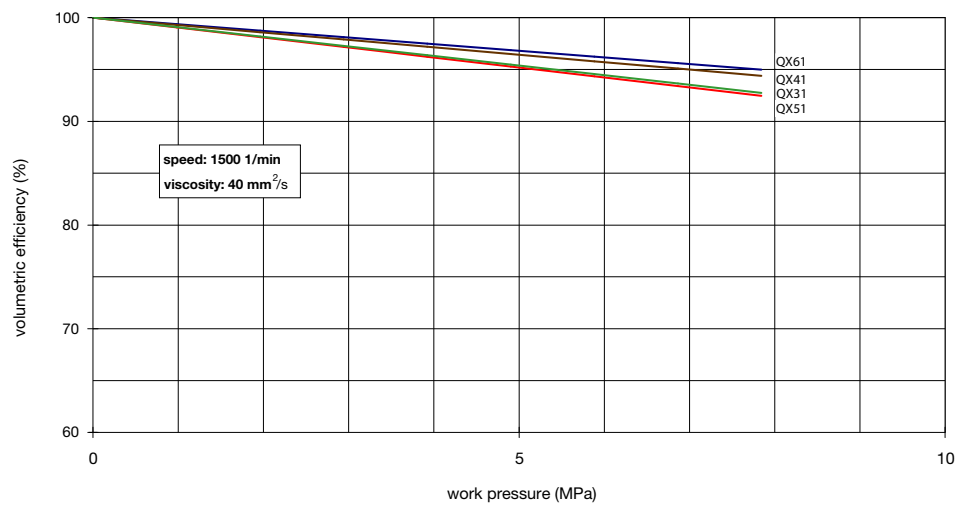

OVERALL EFFICIENCY

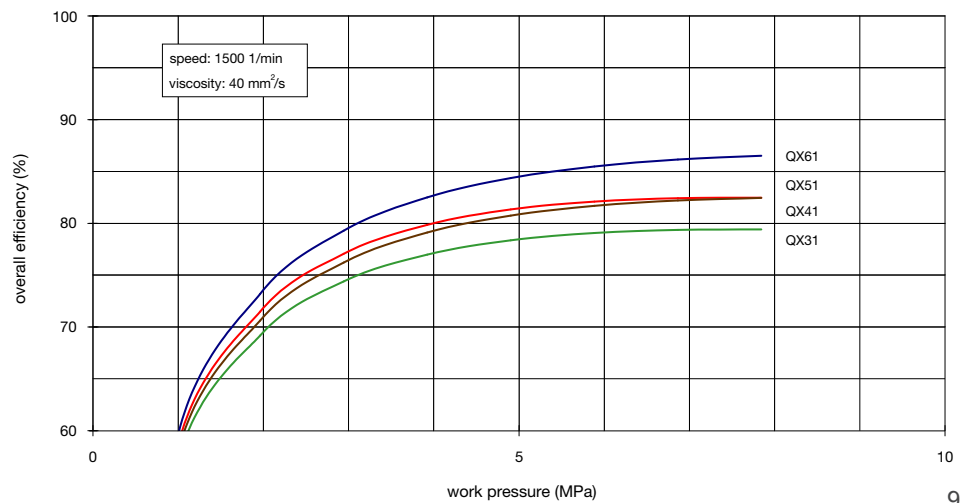

# CHARACTERISTIC CURVES I

## MEDIUM PRESSURE PUMPS: CHARACTERISTIC CURVES

NOISE LEVEL

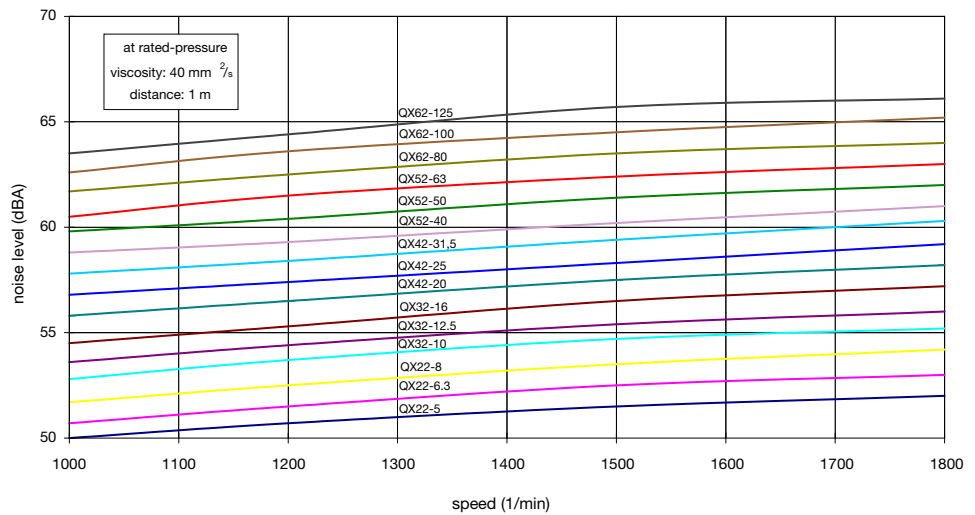

VOLUMETRIC EFFICIENCY

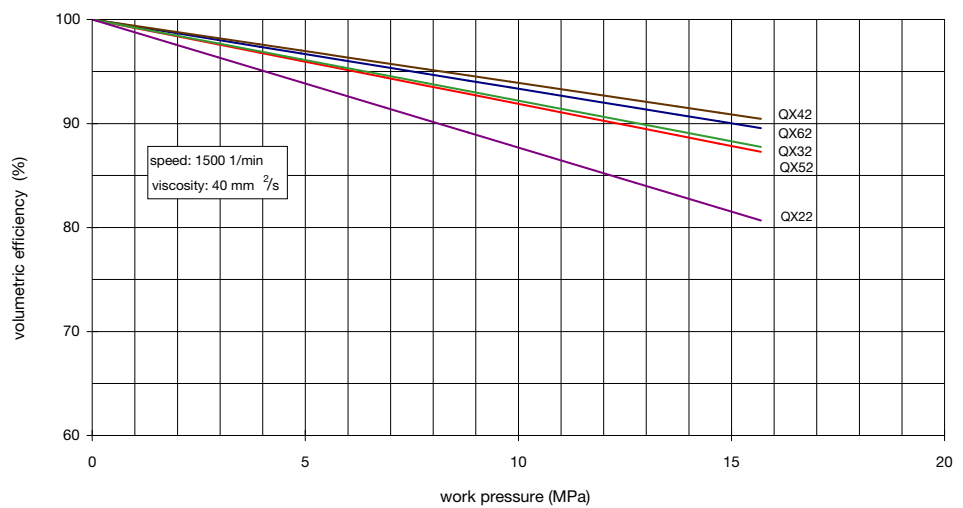

OVERALL EFFICIENCY

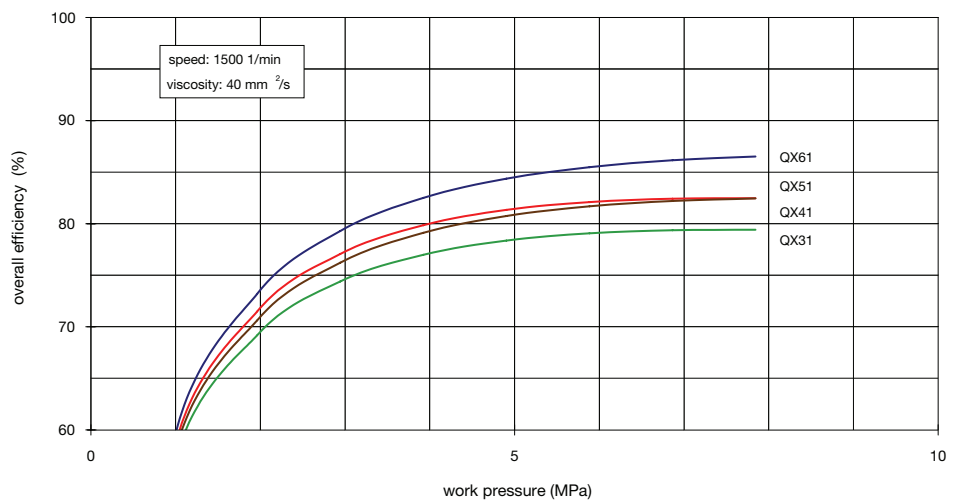

HIGH PRESSURE PUMPS: CHARACTERISTIC CURVES

NOISE LEVEL

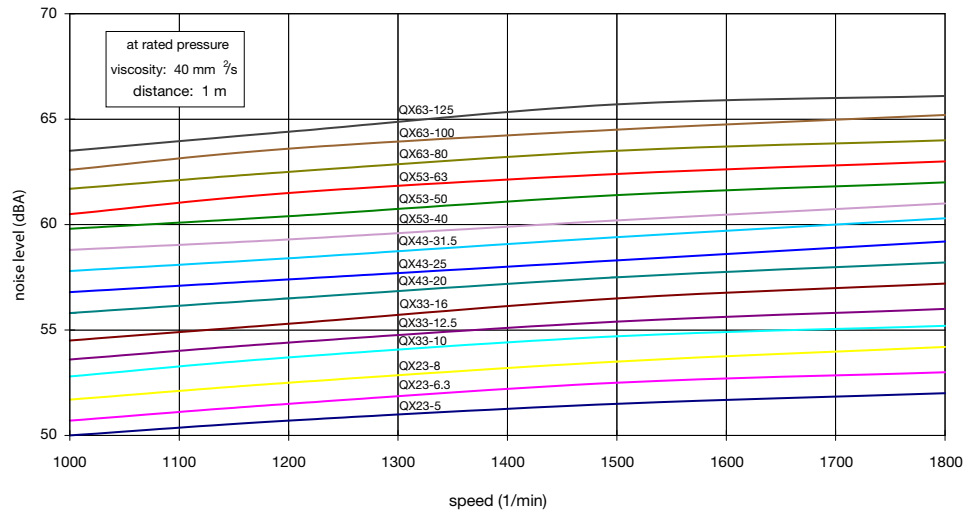

VOLUMETRIC EFFICIENCY

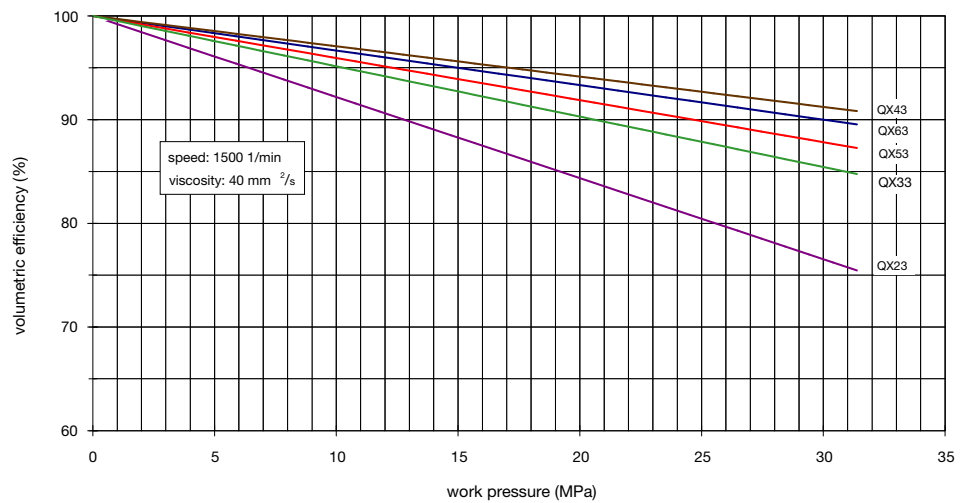

OVERALL EFFICIENCY

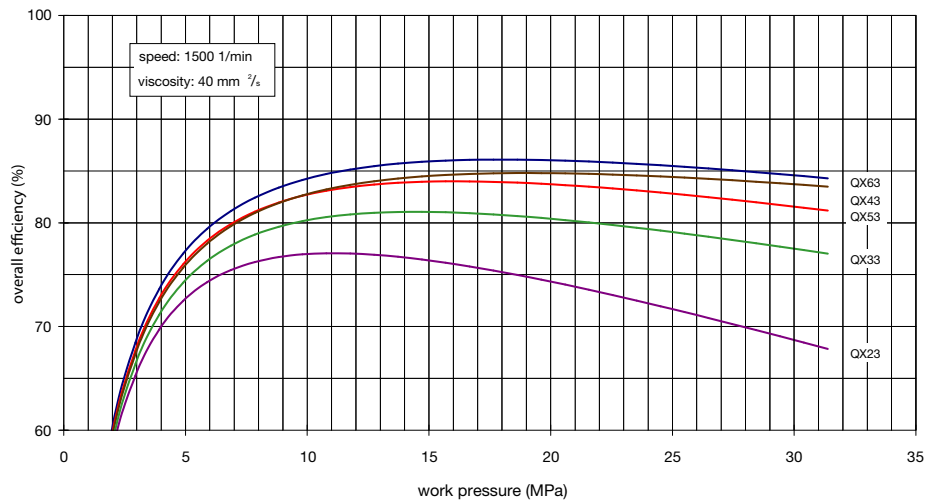

# CHARACTERISTIC CURVES I

## EXTREME PRESSURE PUMPS: CHARACTERISTIC CURVES

NOISE LEVEL

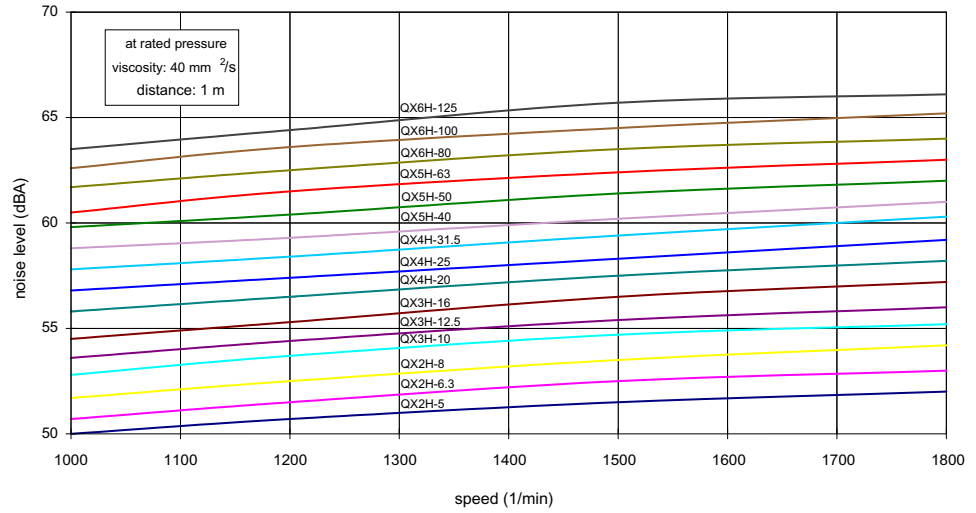

VOLUMETRIC EFFICIENCY

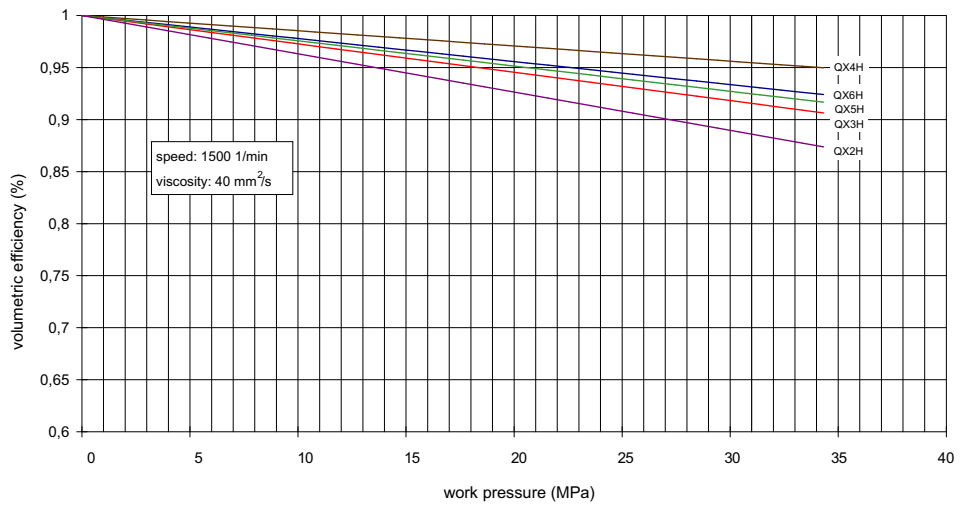

OVERALL EFFICIENCY

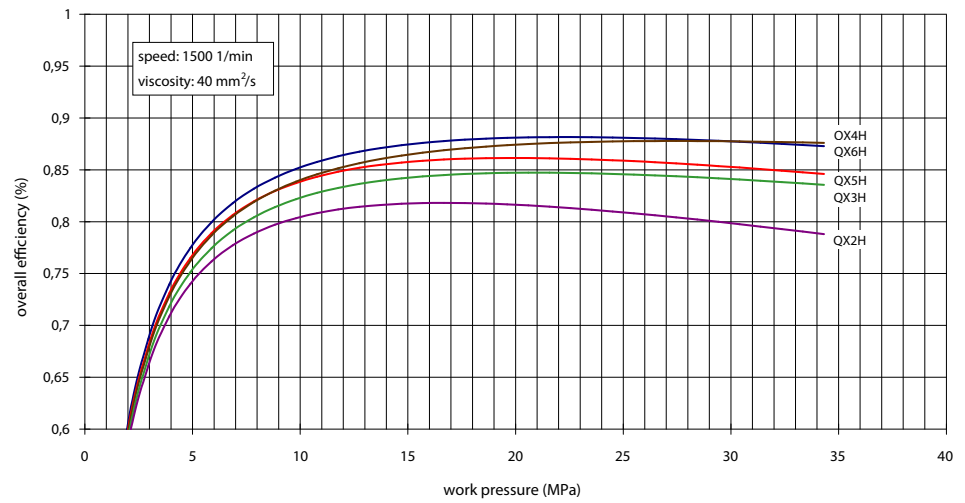

# Programme Single Internal Gear Pumps QX

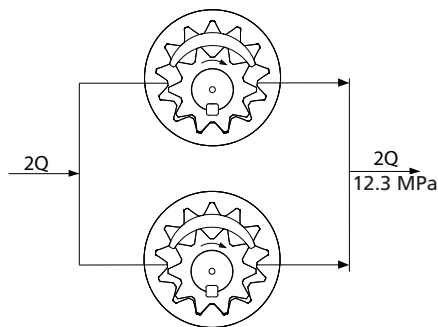

QX line   Low pressure	
Maximum pressure	12.3 MPa
Rated pressure	9.8 MPa
Capacity	10–250 cm <sup>3</sup>

### Low pressure pumps

The QX low pressure line is designed for high capacities at low pressures. This is achieved with the use of two gear pairs arranged in parallel capable of doubling the capacity at low pulsation.

Range of application: machine tools, subassemblies, cooling and lubrication systems

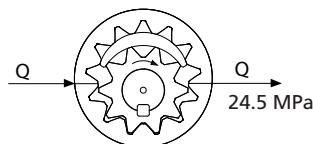

QX line   Medium pressure	
Maximum pressure	24.5 MPa
Rated pressure	20.6 MPa
Capacity	5–125 cm <sup>3</sup>

### Medium pressure pumps

The basic model of the new QX line is equipped with a set of gear wheels for the medium pressure range.

Range of application: injection moulding machines, subassemblies and machine tools

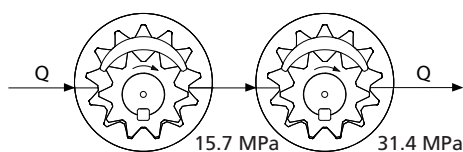

QX line   High pressure	
Maximum pressure	31.4 MPa
Rated pressure	24.5 MPa
Capacity	5–125 cm <sup>3</sup>

### High pressure pumps

For the high pressure range, the gearwheels of the QX series are arranged in a row. The first gearwheel generates a pressure of up to 15.7 MPa and transports the medium to the second gearwheel capable of generating a pressure of up to 31.4 MPa. The noise formation decreases with increasing pressure.

Range of application: hydraulic presses, elevator technology and subassemblies

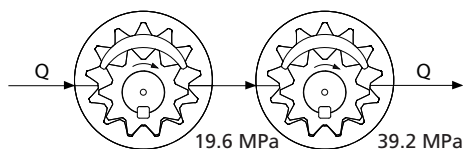

QX line   Extreme pressure	
Maximum pressure	39.2 MPa
Rated pressure	31.4 MPa
Capacity	5–125 cm <sup>3</sup>

### Extreme pressure pumps

The extreme pressure pumps are designed identical to the high pressure pumps but are capable of generating a maximum pressure of up to 39.2 MPa. Thanks to the new gearing geometry, the noise emissions and pulsations are low even in the extreme pressure range.

Range of application: laboratory and testing machines, hydraulic presses

# SINGLE PUMPS I

## LOW PRESSURE PUMPS: PERFORMANCE DATA

Rotational speed 1/min	Pump model	Theoretical capacity cm <sup>3</sup> /rev	Capacity (l/min)									Power consumption (kW)							
			Pressure (MPa)									Pressure (MPa)							
			0.5 (5)	2.0 (20)	3.4 (35)	4.9 (50)	6.9 (70)	7.8 (80)	9.8 (100)	12.3 (125)	0.5 (5)	2.0 (20)	3.4 (35)	4.9 (50)	6.9 (70)	7.8 (80)	9.8 (100)	12.3 (125)	
1000	QX31	-20	20.0	19.8	19.3	18.8	18.3	17.6	17.3	16.6	15.7	0.3	0.9	1.4	1.9	2.6	3.0	3.7	4.6
		-25	25.2	25.0	24.5	24.0	23.5	22.8	22.5	21.8	20.9	0.4	1.1	1.8	2.4	3.3	3.8	4.7	5.8
		-31.5	31.2	31.0	30.5	30.0	29.5	28.8	28.5	27.8	26.9	0.5	1.3	2.2	3.0	4.1	4.6	5.7	7.1
	QX41	-40	40.6	40.3	39.5	38.8	38.0	36.9	36.4	35.3	34.0	0.7	1.7	2.8	3.8	5.3	6.0	7.4	9.2
		-50	50.2	49.9	49.1	48.4	47.6	46.5	46.0	44.9	43.6	0.8	2.1	3.4	4.7	6.5	7.3	9.1	11.2
		-63	64.6	64.3	63.5	62.8	62.0	60.9	60.4	59.3	58.0	1.1	2.7	4.4	6.0	8.3	9.4	11.6	14.4
	QX51	-80	78.4	78.0	76.8	75.6	74.3	72.7	71.9	70.3	68.2	1.3	3.3	5.3	7.3	10.0	11.3	14.0	17.3
		-100	101.0	101	99.4	98.2	96.9	95.3	94.5	92.9	90.8	1.6	4.2	6.8	9.3	12.7	14.4	17.9	22.1
		-125	127.0	127	125	124	123	121	120	119	117	2.0	5.2	8.4	11.6	15.9	18.0	22.3	27.6
	QX61	-160	160.2	159	157	154	152	149	147	144	140	2.6	6.6	10.6	14.6	19.9	22.6	27.9	34.6
		-200	201.8	201	199	196	194	190	189	185	181	3.2	8.2	13.2	18.2	24.9	28.2	34.9	43.2
		-250	249.2	248	246	243	241	238	236	233	229	4.0	10.1	16.2	22.4	30.5	34.6	42.8	53.0
1200	QX31	-20	20.0	23.8	23.3	22.8	22.3	21.6	21.3	20.6	19.7	0.4	1.1	1.7	2.4	3.2	3.6	4.5	5.6
		-25	25.2	30.1	29.6	29.0	28.5	27.8	27.5	26.8	26.0	0.5	1.3	2.1	2.9	4.0	4.6	5.6	7.0
		-31.5	31.2	37.3	36.8	36.2	35.7	35.0	34.7	34.0	33.2	0.7	1.7	2.6	3.6	4.9	5.6	6.9	8.6
	QX41	-40	40.6	48.5	47.7	46.9	46.1	45.0	44.5	43.4	42.1	0.9	2.1	3.4	4.7	6.4	7.2	8.9	11.0
		-50	50.2	60.0	59.2	58.4	57.6	56.5	56.0	55.0	53.6	1.1	2.6	4.2	5.8	7.8	8.9	11.0	13.6
		-63	64.6	77.3	76.5	75.7	74.9	73.8	73.3	72.2	70.9	1.4	3.4	5.4	7.3	10.0	11.3	14.0	17.3
	QX51	-80	78.4	93.7	92.5	91.2	90.0	88.4	87.6	85.9	83.9	1.6	4.1	6.5	8.9	12.1	13.7	16.9	20.9
		-100	101.0	121	120	118	117	116	115	113	111	2.1	5.2	8.3	11.3	15.4	17.5	21.6	26.7
		-125	127.0	152	151	150	148	147	146	144	142	2.6	6.5	10.3	14.2	19.3	21.8	26.9	33.3
	QX61	-160	160.2	191	189	186	184	181	179	176	172	3.3	8.1	12.9	17.7	24.1	27.3	33.7	41.7
		-200	201.8	241	239	236	234	231	229	226	222	4.2	10.2	16.2	22.2	30.2	34.2	42.2	52.2
		-250	249.2	298	296	293	291	288	286	283	279	5.1	12.5	19.9	27.2	37.0	41.9	51.8	64.0
1500	QX31	-20	20.0	29.8	29.3	28.8	28.3	27.6	27.3	26.6	25.7	0.6	1.4	2.2	3.0	4.1	4.6	5.7	7.0
		-25	25.2	37.6	37.1	36.6	36.1	35.4	35.1	34.4	33.5	0.8	1.8	2.8	3.8	5.1	5.8	7.1	8.8
		-31.5	31.2	46.6	46.1	45.6	45.1	44.4	44.1	43.4	42.5	0.9	2.2	3.4	4.6	6.3	7.1	8.7	10.8
	QX41	-40	40.6	60.6	59.8	59.1	58.3	57.2	56.7	55.6	54.3	1.2	2.8	4.4	6.0	8.1	9.2	11.3	13.9
		-50	50.2	75.0	74.3	73.5	72.7	71.6	71.1	70.0	68.7	1.5	3.4	5.4	7.3	9.9	11.2	13.8	17.1
		-63	64.6	96.6	95.8	95.1	94.3	93.2	92.7	91.6	90.3	1.9	4.4	6.9	9.4	12.7	14.4	17.7	21.8
	QX51	-80	78.4	117	116	115	114	112	111	109	107	2.3	5.3	8.3	11.3	15.3	17.3	21.3	26.4
		-100	101.0	151	150	149	147	146	145	143	141	2.9	6.8	10.6	14.5	19.6	22.2	27.3	33.7
		-125	127.0	190	189	188	186	185	184	182	180	3.7	8.5	13.3	18.1	24.5	27.7	34.1	42.1
	QX61	-160	160.2	239	237	235	232	229	227	224	220	4.6	10.6	16.6	22.6	30.6	34.6	42.7	52.7
		-200	201.8	302	299	297	294	291	290	286	282	5.8	13.8	20.8	28.3	38.3	43.3	53.3	65.9
		-250	249.2	373	371	368	366	362	361	357	353	7.2	16.4	25.6	34.8	47.0	53.2	65.4	80.8
1800	QX31	-20	20.0	35.8	35.3	34.8	34.3	33.6	33.3	32.6	31.7	0.8	1.8	2.7	3.7	5.0	5.6	6.9	8.5
		-25	25.2	45.2	44.7	44.2	43.7	43.0	42.6	41.9	41.1	1.0	2.2	3.4	4.6	6.2	7.0	8.6	10.6
		-31.5	31.2	56.0	55.5	55.0	54.5	53.8	53.4	52.7	51.9	1.2	2.7	4.2	5.7	7.6	8.6	10.6	13.1
	QX41	-40	40.6	72.8	72.0	71.2	70.4	69.4	68.9	67.8	66.5	1.6	3.5	5.4	7.3	9.9	11.1	13.7	16.9
		-50	50.2	90.1	89.3	88.5	87.7	86.7	86.1	85.1	83.8	2.0	4.3	6.6	9.0	12.1	13.7	16.8	20.7
		-63	64.6	116	115	114	114	113	112	111	110	2.5	5.5	8.5	11.5	15.5	17.5	21.5	26.4
	QX51	-80	78.4	141	139	138	137	135	135	133	131	3.0	6.6	10.2	13.9	18.7	21.1	25.9	31.9
		-100	101.0	181	180	179	178	176	175	174	172	3.9	8.5	13.1	17.7	23.9	26.9	33.1	40.8
		-125	127.0	228	227	226	225	223	222	220	218	4.9	10.6	16.4	22.1	29.8	33.6	41.3	50.9
	QX61	-160	160.2	288	285	283	280	277	275	272	268	6.1	13.3	20.5	27.7	37.3	42.1	51.8	63.8
		-200	201.8	362	360	357	355	352	350	347	343	7.7	16.7	25.7	34.7	46.7	52.7	64.7	79.7
		-250	249.2	448	445	443	440	437	435	432	428	9.5	20.5	31.6	42.6	57.3	64.7	79.4	97.8

MEDIUM PRESSURE PUMPS: PERFORMANCE DATA

Rotational speed 1/min	Pump model	Theoretical capacity cm <sup>3</sup> /rev	Capacity (l/min)									Power consumption (kW)							
			Pressure (MPa)									Pressure (MPa)							
			0.5 (5)	3.4 (35)	6.9 (70)	10.3 (105)	13.7 (140)	15.7 (160)	20.6 (210)	24.5 (250)	0.5 (5)	3.4 (35)	6.9 (70)	10.3 (105)	13.7 (140)	15.7 (160)	20.6 (210)	24.5 (250)	
1000	QX22*	-5	5.5	5.4	5.0	4.5	4.1	4.0	3.8			0.1	0.4	0.7	1.1	1.3	1.5		
		-6.3	6.7	6.6	6.2	5.7	5.2	5.2	5.0			0.1	0.5	0.8	1.3	1.6	1.8		
		-8	8.3	8.2	7.8	7.3	6.9	6.8	6.6			0.1	0.6	1.0	1.6	2.0	2.3		
	QX32	-10	10.0	9.9	9.4	8.9	8.3	7.7	7.4	6.6	5.9	0.2	0.7	1.3	1.9	2.5	2.9	3.7	4.4
		-12.5	12.6	12.5	12.0	11.5	10.9	10.3	10.0	9.2	8.5	0.2	0.9	1.6	2.4	3.2	3.6	4.7	5.5
		-16	15.6	15.5	15.0	14.5	13.9	13.3	13.0	12.2	11.5	0.3	1.1	2.0	2.9	3.9	4.4	5.8	6.8
		-20	20.3	20.2	19.4	18.5	17.7	16.8	16.3	15.0	13.9	0.3	1.4	2.6	3.8	5.0	5.7	7.5	8.9
		-25	25.1	25.0	24.2	23.3	22.5	21.6	21.1	19.8	18.8	0.4	1.7	3.2	4.7	6.2	7.1	9.2	10.9
		-31.5	32.3	32.2	31.4	30.5	29.7	28.8	28.3	27.0	26.0	0.5	2.2	4.1	6.0	7.9	9.0	11.8	14.0
	QX42	-40	39.2	39.0	37.9	36.6	35.2	33.9	33.1	31.3	29.7	0.6	2.6	5.0	7.3	9.6	10.9	14.3	16.9
		-50	50.5	50.3	49.2	47.9	46.5	45.2	44.4	42.6	41.0	0.8	3.4	6.4	9.3	12.3	14.0	18.3	21.7
		-63	63.5	63.3	62.2	60.9	59.5	58.2	57.4	55.6	54.0	1.0	4.2	8.0	11.7	15.4	17.6	22.9	27.2
QX52	-80	80.1	79.8	77.7	75.2	72.8	70.4	69.0	65.5	62.8	1.3	5.3	10.0	14.7	19.4	22.1	28.8	34.1	
	-100	100.9	101	98.5	96.0	93.6	91.2	89.8	86.3	83.6	1.6	6.7	12.5	18.4	24.3	27.7	36.1	42.8	
	-125	124.6	124	122	120	117	115	113	110	107	2.0	8.2	15.4	22.7	29.9	34.1	44.4	52.7	
1200	QX22*	-5	5.5	6.5	6.2	5.6	5.2	5.0	4.9			0.1	0.5	0.8	1.3	1.6	1.8		
		-6.3	6.7	7.9	7.5	7.0	6.6	6.5	6.3			0.1	0.6	1.0	1.5	1.9	2.2		
		-8	8.3	9.9	9.5	8.9	8.6	8.4	8.2			0.2	0.7	1.2	1.9	2.4	2.7		
	QX32	-10	10.0	11.9	11.5	10.9	10.4	9.8	9.5	8.8	8.1	0.2	0.8	1.6	2.3	3.0	3.4	4.5	5.3
		-12.5	12.6	15.0	14.6	14.0	13.5	13.0	12.6	11.9	11.3	0.3	1.1	2.0	2.9	3.8	4.3	5.6	6.7
		-16	15.6	18.6	18.2	17.6	17.1	16.6	16.2	15.5	14.9	0.3	1.3	2.4	3.6	4.7	5.3	6.9	8.2
		-20	20.3	24.2	23.5	22.7	21.8	21.0	20.5	19.3	18.3	0.4	1.7	3.1	4.6	6.1	6.9	9.0	10.7
		-25	25.1	30.0	29.3	28.4	27.6	26.8	26.3	25.1	24.1	0.5	2.1	3.9	5.7	7.5	8.5	11.1	13.1
		-31.5	32.3	38.6	37.9	37.1	36.2	35.4	34.9	33.7	32.7	0.7	2.7	5.0	7.3	9.6	10.9	14.2	16.8
	QX42	-40	39.2	46.9	45.8	44.5	43.2	42.0	41.3	39.5	38.0	0.8	3.2	6.0	8.8	11.6	13.2	17.2	20.4
		-50	50.5	60.4	59.3	58.1	56.8	55.5	54.8	53.0	51.6	1.1	4.1	7.7	11.3	14.9	16.9	22.0	26.1
		-63	63.5	76.0	74.9	73.7	72.4	71.1	70.4	68.6	67.2	1.3	5.2	9.7	14.1	18.6	21.2	27.6	32.7
QX52	-80	80.1	95.8	93.8	91.5	89.2	86.8	85.5	82.2	79.6	1.7	6.5	12.1	17.8	23.4	26.6	34.6	41.1	
	-100	100.9	121	119	116	114	112	110	107	105	2.1	8.2	15.2	22.3	29.3	33.4	43.5	51.5	
	-125	124.6	149	147	145	143	140	139	136	133	2.6	10.0	18.7	27.4	36.1	41.1	53.5	63.4	
1500	QX22	-4**	4.3	6.4	6.0	5.6	5.2	4.8				0.1	0.5	0.9	1.3	1.7			
		-5	5.5	8.2	7.8	7.4	7.0	6.6	6.3	5.7	5.2	0.2	0.6	1.1	1.6	2.1	2.4	3.1	3.7
		-6.3	6.7	9.9	9.6	9.1	8.7	8.3	8.1	7.4	7.0	0.2	0.7	1.3	1.9	2.6	2.9	3.8	4.5
	QX32	-8	8.3	12.4	12.0	11.6	11.2	10.8	10.5	9.9	9.4	0.2	0.9	1.7	2.4	3.2	3.6	4.7	5.6
		-10	10.0	14.9	14.5	14.0	13.5	13.0	12.7	12.0	11.4	0.3	1.1	2.0	2.9	3.8	4.3	5.6	6.7
		-12.5	12.6	18.8	18.4	17.9	17.4	16.9	16.6	15.9	15.3	0.4	1.4	2.5	3.6	4.8	5.4	7.1	8.4
		-16	15.6	23.3	22.9	22.4	21.9	21.4	21.1	20.4	19.8	0.5	1.7	3.1	4.5	5.9	6.7	8.7	10.3
		-20	20.3	30.3	29.7	28.9	28.1	27.3	26.9	25.7	24.8	0.6	2.2	4.0	5.8	7.6	8.7	11.3	13.4
		-25	25.1	37.5	36.9	36.1	35.3	34.5	34.1	32.9	32.0	0.7	2.7	4.9	7.2	9.4	10.7	13.9	16.5
	QX42	-31.5	32.3	48.3	47.7	46.9	46.1	45.3	44.9	43.7	42.8	0.9	3.4	6.3	9.2	12.1	13.7	17.8	21.1
		-40	39.2	58.6	57.6	56.4	55.3	54.1	53.4	51.7	50.4	1.1	4.1	7.6	11.1	14.6	16.6	21.6	25.6
		-50	50.5	75.6	74.6	73.4	72.2	71.0	70.4	68.7	67.3	1.5	5.3	9.8	14.3	18.7	21.3	27.7	32.8
QX52	-63	63.5	95.1	94.1	92.9	91.7	90.5	89.9	88.2	86.8	1.8	6.6	12.3	17.9	23.5	26.7	34.7	41.1	
	-80	80.1	120	118	116	114	111	110	107	105	2.3	8.4	15.4	22.4	29.5	33.5	43.5	51.6	
	-100	100.9	151	149	147	145	143	141	138	136	2.9	10.5	19.3	28.1	37.0	42.0	54.6	64.7	
1800	QX22	-125	124.6	187	185	183	180	178	177	174	171	3.6	12.9	23.8	34.6	45.5	51.7	67.2	79.6
		-4**	4.3	7.7	7.4	7.0	6.6	6.2	5.9			0.2	0.6	1.1	1.5	2.0	2.3		
		-5	5.5	9.8	9.5	9.1	8.7	8.3	8.1	7.5	7.1	0.2	0.7	1.3	2.0	2.6	2.9	3.8	4.5
	QX32	-6.3	6.7	11.9	11.6	11.2	10.8	10.4	10.2	9.6	9.2	0.3	0.9	1.6	2.4	3.1	3.5	4.6	5.4
		-8	8.3	14.9	14.6	14.2	13.8	13.4	13.1	12.6	12.1	0.3	1.1	2.0	2.9	3.8	4.4	5.7	6.7
		-10	10.0	17.9	17.5	17.1	16.6	16.1	15.8	15.2	14.6	0.4	1.3	2.4	3.5	4.6	5.2	6.8	8.0
		-12.5	12.6	22.6	22.2	21.7	21.3	20.8	20.5	19.9	19.3	0.5	1.7	3.0	4.4	5.8	6.6	8.5	10.1
		-16	15.6	28.0	27.6	27.1	26.7	26.2	25.9	25.3	24.7	0.6	2.1	3.8	5.4	7.1	8.1	10.5	12.5
		-20	20.3	36.4	35.8	35.1	34.3	33.6	33.2	32.1	31.3	0.8	2.7	4.9	7.1	9.2	10.5	13.6	16.1
	QX42	-25	25.1	45.1	44.5	43.7	43.0	42.2	41.8	40.8	39.9	1.0	3.3	6.0	8.7	11.4	12.9	16.8	19.9
		-31.5	32.3	58.0	57.4	56.7	55.9	55.2	54.8	53.7	52.9	1.2	4.2	7.7	11.1	14.6	16.6	21.5	25.5
		-40	39.2	70.4	69.5	68.4	67.3	66.2	65.5	64.0	62.7	1.5	5.1	9.3	13.5	17.7	20.0	26.0	30.8
QX52	-50	50.5	90.7	89.8	88.7	87.6	86.5	85.9	84.3	83.0	1.9	6.5	11.9	17.3	22.6	25.7	33.4	39.5	
	-63	63.5	114	113	112	111	110	109	108	106	2.4	8.2	14.9	21.6	28.4	32.2	41.8	49.5	
	-80	80.1	144	142	140	138	136	135	132	130	3.1	10.3	18.8	27.2	35.6	40.5	52.5	62.2	
QX62	-100	100.9	181	180	178	176	174	172	170	167	3.9	12.9	23.5	34.1	44.7	50.8	65.9	78.0	
	-125	124.6	224	222	220	218	216	215	212	210	4.8	15.9	29.0	42.0	55.0	62.5	81.1	96.0	

\* For models QX22-5, -6.3 and -8, the maximum pressure with rotational speeds of 1000 1/min and 1200 1/min varies depending on the operating conditions. Please contact your local BIBUS representative.

\*\* Please use the maximum pressure (rated pressure) of model QX22-4 for a rotational speed of 1500 1/min at 13.7 MPa (9.8 MPa) and 1800 1/min at 17.7 MPa (12.7 MPa).

# SINGLE PUMPS I

## HIGH PRESSURE PUMPS: PERFORMANCE DATA

Rotational speed 1/min	Pump model	Theoretical capacity cm <sup>3</sup> /rev	Capacity (l/min)							Power consumption (kW)							
			Pressure (MPa)							Pressure (MPa)							
			0.5 (5)	3.4 (35)	6.9 (70)	13.7 (140)	20.6 (210)	24.5 (250)	31.4 (320)	0.5 (5)	3.4 (35)	6.9 (70)	13.7 (140)	20.6 (210)	24.5 (250)	31.4 (320)	
1000	QX23*	-5	5.5	5.0	4.5	4.1	4.0				0.1	0.4	0.7	1.1			
		-6.3	6.7	6.2	5.7	5.2	5.2	4.9			0.1	0.5	0.8	1.3	2.5		
		-8	8.3	7.8	7.3	6.9	6.8	6.5			0.1	0.6	1.0	1.6	3.2		
	QX33	-10	10.0	10.0	9.7	9.3	8.6	7.9	7.5	6.8	0.2	0.8	1.4	2.6	3.8	4.5	5.7
		-12.5	12.6	12.6	12.3	11.9	11.2	10.5	10.1	9.4	0.3	0.9	1.7	3.2	4.8	5.6	7.2
		-16	15.6	15.6	15.3	14.9	14.2	13.5	13.1	12.4	0.4	1.2	2.1	4.0	5.9	6.9	8.8
	QX43	-20	20.3	20.2	19.9	19.5	18.6	17.8	17.3	16.4	0.5	1.5	2.7	5.2	7.6	9.0	11.4
		-25	25.1	25.0	24.7	24.3	23.4	22.6	22.1	21.2	0.6	1.9	3.4	6.4	9.4	11.1	14.1
		-31.5	32.3	32.2	31.9	31.5	30.6	29.8	29.3	28.4	0.7	2.4	4.3	8.2	12.0	14.2	18.0
	QX53	-40	39.2	39.1	38.5	37.8	36.4	35.1	34.3	32.9	0.9	2.9	5.2	9.9	14.5	17.2	21.8
		-50	50.5	50.4	49.8	49.1	47.7	46.4	45.6	44.2	1.2	3.7	6.7	12.7	18.6	22.0	28.0
		-63	63.5	63.4	62.8	62.1	60.7	59.4	58.6	57.2	1.5	4.7	8.4	15.9	23.3	27.6	35.1
QX63	-80	80.1	79.9	78.7	77.3	74.5	71.7	70.1	67.3	1.8	5.9	10.5	19.9	29.3	34.7	44.1	
	-100	100.9	101	99.5	98.1	95.3	92.5	90.9	88.1	2.3	7.3	13.2	25.0	36.8	43.5	55.3	
	-125	124.6	124	123	122	119	116	115	112	2.8	9.0	16.3	30.8	45.2	53.5	68.0	
1200	QX23*	-5	5.5	6.5	6.2	5.6	5.2	5.0			0.1	0.5	0.8	1.3	1.6		
		-6.3	6.7	7.9	7.5	7.0	6.6	6.5			0.1	0.6	1.0	1.5	1.9		
		-8	8.3	9.9	9.5	8.9	8.6	8.4			0.2	0.7	1.2	1.9	2.4		
	QX33	-10	10.0	12.0	11.7	11.3	10.7	10.0	9.6	8.9	0.3	0.9	1.7	3.1	4.6	5.4	6.9
		-12.5	12.6	15.1	14.8	14.5	13.8	13.1	12.7	12.0	0.4	1.2	2.1	3.9	5.8	6.8	8.6
		-16	15.6	18.7	18.4	18.1	17.4	16.7	16.3	15.6	0.5	1.5	2.6	4.8	7.1	8.4	10.6
	QX43	-20	20.3	24.3	24.0	23.6	22.7	21.9	21.5	20.7	0.6	1.9	3.3	6.3	9.2	10.9	13.8
		-25	25.1	30.1	29.7	29.3	28.5	27.7	27.2	26.4	0.8	2.3	4.1	7.7	11.3	13.4	17.0
		-31.5	32.3	38.7	38.4	38.0	37.1	36.3	35.9	35.1	1.0	3.0	5.3	9.9	14.5	17.1	21.8
	QX53	-40	39.2	47.0	46.4	45.7	44.4	43.1	42.3	41.0	1.2	3.6	6.4	12.0	17.5	20.7	26.3
		-50	50.5	60.5	59.9	59.3	58.0	56.7	55.9	54.6	1.5	4.6	8.2	15.3	22.5	26.6	33.8
		-63	63.5	76.1	75.5	74.9	73.6	72.3	71.5	70.2	1.9	5.8	10.3	19.2	28.2	33.3	42.3
QX63	-80	80.1	95.9	94.8	93.5	90.8	88.1	86.6	83.9	2.4	7.3	12.9	24.2	35.4	41.8	53.1	
	-100	100.9	121	120	118	116	113	112	109	3.1	9.1	16.2	30.3	44.4	52.5	66.6	
	-125	124.6	149	148	147	144	142	140	137	3.8	11.2	19.9	37.3	54.7	64.6	82.0	
1500	QX23	-4**	4.3	6.4	6.2	6.9	5.4	4.8			0.2	0.5	0.9	1.7	2.6		
		-5	5.5	8.2	8.0	7.7	7.2	6.6	6.3	5.8	0.2	0.7	1.2	2.2	3.2	3.8	4.8
		-6.3	6.7	9.9	9.7	9.4	8.9	8.4	8.1	7.5	0.3	0.8	1.4	2.7	3.9	4.6	5.8
	QX33	-8	8.3	12.4	12.2	11.9	11.4	10.8	10.5	10.0	0.4	1.0	1.8	3.3	4.8	5.7	7.2
		-10	10.0	15.0	14.7	14.4	13.7	13.1	12.8	12.1	0.4	1.2	2.1	4.0	5.8	6.8	8.6
		-12.5	12.6	18.9	18.6	18.3	17.6	17.0	16.7	16.0	0.6	1.5	2.7	5.0	7.3	8.6	10.9
	QX43	-16	15.6	23.4	23.1	22.8	22.1	21.5	21.2	20.5	0.7	1.9	3.3	6.1	9.0	10.6	13.4
		-20	20.3	30.4	30.1	29.7	28.9	28.2	27.8	27.0	0.9	2.5	4.3	7.9	11.6	13.7	17.3
		-25	25.1	37.6	37.3	36.9	36.1	35.4	35.0	34.2	1.1	3.0	5.3	9.8	14.3	16.9	21.4
	QX53	-31.5	32.3	48.4	48.1	47.7	46.9	46.2	45.8	45.0	1.4	3.9	6.8	12.5	18.3	21.6	27.4
		-40	39.2	58.7	58.2	57.6	56.3	55.1	54.4	53.2	1.7	4.7	8.2	15.2	22.2	26.1	33.1
		-50	50.5	75.7	75.1	74.5	73.3	72.1	71.4	70.1	2.2	6.1	10.5	19.5	28.4	33.5	42.5
QX63	-63	63.5	95.2	94.6	94.0	92.8	91.6	90.9	89.6	2.8	7.6	13.2	24.4	35.6	42.0	53.2	
	-80	80.1	120	119	118	115	113	111	109	3.5	9.5	16.6	30.6	44.7	52.8	66.8	
	-100	100.9	151	150	149	146	144	142	140	4.4	12.0	20.8	38.5	56.1	66.2	83.9	
1800	QX23	-125	124.6	187	186	184	182	179	178	176	5.4	14.7	25.6	47.3	69.0	81.5	103
		-4**	4.3	7.7	7.5	7.2	6.7	6.2	6.0		0.3	0.7	1.1	2.1	3.1	3.6	
		-5	5.5	9.9	9.7	9.4	8.9	8.4	8.1	7.6	0.3	0.9	1.5	2.7	3.9	4.6	5.8
	QX33	-6.3	6.7	11.9	11.7	11.5	11.0	10.5	10.2	9.7	0.4	1.0	1.8	3.2	4.7	5.5	7.0
		-8	8.3	14.9	14.7	14.4	13.9	13.4	13.2	12.7	0.5	1.3	2.2	4.0	5.8	6.9	8.7
		-10	10.0	18.0	17.7	17.4	16.8	16.2	15.9	15.3	0.6	1.5	2.6	4.8	7.0	8.3	10.4
	QX43	-12.5	12.6	22.6	22.4	22.1	21.5	20.9	20.6	20.0	0.8	1.9	3.3	6.1	8.8	10.4	13.1
		-16	15.6	28.0	27.8	27.5	26.9	26.3	26.0	25.4	0.9	2.4	4.1	7.5	10.9	12.8	16.2
		-20	20.3	36.5	36.2	35.8	35.1	34.4	34.0	33.3	1.2	3.1	5.3	9.7	14.1	16.6	20.9
	QX53	-25	25.1	45.1	44.8	44.5	43.8	43.1	42.7	42.0	1.5	3.8	6.5	11.9	17.3	20.4	25.8
		-31.5	32.3	58.1	57.8	57.4	56.7	56.0	55.6	54.9	1.9	4.9	8.4	15.3	22.2	26.2	33.1
		-40	39.2	70.5	70.0	69.4	68.3	67.1	66.5	65.3	2.3	5.9	10.1	18.5	26.8	31.6	40.0
QX63	-50	50.5	90.8	90.3	89.8	88.6	87.5	86.8	85.7	3.0	7.6	13.0	23.7	34.4	40.6	51.3	
	-63	63.5	114	114	113	112	111	110	109	3.8	9.5	16.3	29.7	43.1	50.8	64.3	
	-80	80.1	144	143	142	140	137	136	134	4.7	12.0	20.4	37.3	54.2	63.9	80.7	
	-100	100.9	181	180	179	177	175	173	171	6.0	15.1	25.6	46.8	68.0	80.1	101	
	-125	124.6	224	223	222	220	217	216	214	7.4	18.5	31.6	57.6	83.7	98.6	125	

\* For models QX23-5, -6.3 and -8, the maximum pressure with rotational speeds of 1000 1/min and 1200 1/min varies depending on the operating conditions. Please contact your local BIBUS representative.

\*\* Please use the maximum pressure (rated pressure) of model QX23-4 for a rotational speed of 1500 1/min at 21.6 MPa (15.7 MPa) and 1800 1/min at 27.5 MPa (20.6 MPa).



## EXTREME PRESSURE PUMPS: PERFORMANCE DATA

Rotational speed 1/min	Pump model	Theoretical capacity cm³/rev	Capacity (l/min)									Power consumption (kW)								
			Pressure (MPa)									Pressure (MPa)								
			0.5 (5)	3.4 (35)	6.9 (70)	13.7 (140)	20.6 (210)	24.5 (250)	31.4 (320)	39.2 (400)	0.5 (5)	3.4 (35)	6.9 (70)	13.7 (140)	20.6 (210)	24.5 (250)	31.4 (320)	39.2 (400)		
1000	QX2H*	-5	5.5																	
		-6.3	6.7																	
		-8	8.3																	
	QX3H	-10	10.0	10.0	9.7	9.3	8.6	7.9	7.5	6.8	6.0	0.2	0.8	1.4	2.6	3.8	4.5	5.7	7.1	
		-12.5	12.6	12.6	12.3	11.9	11.2	10.5	10.1	9.4	8.6	0.3	0.9	1.7	3.2	4.8	5.6	7.2	8.9	
		-16	15.6	15.6	15.3	14.9	14.2	13.5	13.1	12.4	11.6	0.4	1.2	2.1	4.0	5.9	6.9	8.8	11.0	
	QX4H	-20	20.3	20.2	19.9	19.5	18.6	17.8	17.3	16.4	15.5	0.5	1.5	2.7	5.2	7.6	9.0	11.4	14.2	
		-25	25.1	25.0	24.7	24.3	23.4	22.6	22.1	21.2	20.3	0.6	1.9	3.4	6.4	9.4	11.1	14.1	17.5	
		-31.5	32.3	32.2	31.9	31.5	30.6	29.8	29.3	28.4	27.5	0.7	2.4	4.3	8.2	12.0	14.2	18.0	22.4	
	QX5H	-40	39.2	39.1	38.5	37.8	36.4	35.1	34.3	32.9	31.3	0.9	2.9	5.2	9.9	14.5	17.2	21.8	27.1	
		-50	50.5	50.4	49.8	49.1	47.7	46.4	45.6	44.2	42.6	1.2	3.7	6.7	12.7	18.6	22.0	28.0	34.8	
		-63	63.5	63.4	62.8	62.1	60.7	59.4	58.6	57.2	55.6	1.5	4.7	8.4	15.9	23.3	27.6	35.1	43.6	
	QX6H	-80	80.1	79.9	78.7	77.3	74.5	71.7	70.1	67.3	64.2	1.8	5.9	10.5	19.9	29.3	34.7	44.1	54.8	
		-100	100.9	101	99.5	98.1	95.3	92.5	90.9	88.1	85.0	2.3	7.3	13.2	25.0	36.8	43.5	55.3	68.7	
		-125	124.6	124	123	122	119	116	115	112	109	2.8	9.0	16.3	30.8	45.2	53.5	68.0	84.5	
1200	QX2H*	-5	5.5																	
		-6.3	6.7																	
		-8	8.3																	
	QX3H	-10	10.0	12.0	11.7	11.3	10.7	10.0	9.6	8.9	8.1	0.3	0.9	1.7	3.1	4.6	5.4	6.9	8.5	
		-12.5	12.6	15.1	14.8	14.5	13.8	13.1	12.7	12.0	11.3	0.4	1.2	2.1	3.9	5.8	6.8	8.6	10.7	
		-16	15.6	18.7	18.4	18.1	17.4	16.7	16.3	15.6	14.9	0.5	1.5	2.6	4.8	7.1	8.4	10.6	13.2	
	QX4H	-20	20.3	24.3	24.0	23.6	22.7	21.9	21.5	20.7	19.7	0.6	1.9	3.3	6.3	9.2	10.9	13.8	17.1	
		-25	25.1	30.1	29.7	29.3	28.5	27.7	27.2	26.4	25.5	0.8	2.3	4.1	7.7	11.3	13.4	17.0	21.1	
		-31.5	32.3	38.7	38.4	38.0	37.1	36.3	35.9	35.1	34.1	1.0	3.0	5.3	9.9	14.5	17.1	21.8	27.0	
	QX5H	-40	39.2	47.0	46.4	45.7	44.4	43.1	42.3	41.0	39.5	1.2	3.6	6.4	12.0	17.5	20.7	26.3	32.7	
		-50	50.5	60.5	59.9	59.3	58.0	56.7	55.9	54.6	53.1	1.5	4.6	8.2	15.3	22.5	26.6	33.8	41.9	
		-63	63.5	76.1	75.5	74.9	73.6	72.3	71.5	70.2	68.7	1.9	5.8	10.3	19.2	28.2	33.3	42.3	52.5	
	QX6H	-80	80.1	95.9	94.8	93.5	90.8	88.1	86.6	83.9	80.9	2.4	7.3	12.9	24.2	35.4	41.8	53.1	66.0	
		-100	100.9	121	120	118	116	113	112	109	106	3.1	9.1	16.2	30.3	44.4	52.5	66.6	82.8	
		-125	124.6	149	148	147	144	142	140	137	134	3.8	11.2	19.9	37.3	54.7	64.6	82.0	102	
1500	QX2H	-5	5.1	8.2	8.0	7.7	7.2	6.6	6.3	5.8	5.2	0.2	0.7	1.2	2.2	3.2	3.8	4.8	6.0	
		-6.3	6.3	9.9	9.7	9.4	8.9	8.4	8.1	7.5	6.9	0.3	0.8	1.4	2.7	3.9	4.6	5.8	7.2	
		-8	7.9	12.4	12.2	11.9	11.4	10.8	10.5	10.0	9.4	0.4	1.0	1.8	3.3	4.8	5.7	7.2	8.9	
	QX3H	-10	10.0	15.0	14.7	14.4	13.7	13.1	12.8	12.1	11.4	0.4	1.2	2.1	4.0	5.8	6.8	8.6	10.7	
		-12.5	12.6	18.9	18.6	18.3	17.6	17.0	16.7	16.0	15.3	0.6	1.5	2.7	5.0	7.3	8.6	10.9	13.5	
		-16	15.6	23.4	23.1	22.8	22.1	21.5	21.2	20.5	19.8	0.7	1.9	3.3	6.1	9.0	10.6	13.4	16.6	
	QX4H	-20	20.3	30.4	30.1	29.7	28.9	28.2	27.8	27.0	26.1	0.9	2.5	4.3	7.9	11.6	13.7	17.3	21.5	
		-25	25.1	37.6	37.3	36.9	36.1	35.4	35.0	34.2	33.3	1.1	3.0	5.3	9.8	14.3	16.9	21.4	26.5	
		-31.5	32.3	48.4	48.1	47.7	46.9	46.2	45.8	45.0	44.1	1.4	3.9	6.8	12.5	18.3	21.6	27.4	34.0	
	QX5H	-40	39.2	58.7	58.2	57.6	56.3	55.1	54.4	53.2	51.8	1.7	4.7	8.2	15.2	22.2	26.1	33.1	41.1	
		-50	50.5	75.7	75.1	74.5	73.3	72.1	71.4	70.1	68.7	2.2	6.1	10.5	19.5	28.4	33.5	42.5	52.7	
		-63	63.5	95.2	94.6	94.0	92.8	91.6	90.9	89.6	88.2	2.8	7.6	13.2	24.4	35.6	42.0	53.2	66.0	
	QX6H	-80	80.1	120	119	118	115	113	111	109	106	3.5	9.5	16.6	30.6	44.7	52.8	66.8	82.9	
		-100	100.9	151	150	149	146	144	142	140	137	4.4	12.0	20.8	38.5	56.1	66.2	83.9	104	
		-125	124.6	187	186	184	182	179	178	176	173	5.4	14.7	25.6	47.3	69.0	81.5	103	128	
1800	QX2H	-5	5.5	9.9	9.7	9.4	8.9	8.4	8.1	7.6	7.0	0.3	0.9	1.5	2.7	3.9	4.6	5.8	7.2	
		-6.3	6.7	11.9	11.7	11.5	11.0	10.5	10.2	9.7	9.1	0.4	1.0	1.8	3.2	4.7	5.5	7.0	8.7	
		-8	8.3	14.9	14.7	14.4	13.9	13.4	13.2	12.7	12.1	0.5	1.3	2.2	4.0	5.8	6.9	8.7	10.8	
	QX3H	-10	10.0	18.0	17.7	17.4	16.8	16.2	15.9	15.3	14.6	0.6	1.5	2.6	4.8	7.0	8.3	10.4	12.9	
		-12.5	12.6	22.6	22.4	22.1	21.5	20.9	20.6	20.0	19.3	0.8	1.9	3.3	6.1	8.8	10.4	13.1	16.2	
		-16	15.6	28.0	27.8	27.5	26.9	26.3	26.0	25.4	24.7	0.9	2.4	4.1	7.5	10.9	12.8	16.2	20.0	
	QX4H	-20	20.3	36.5	36.2	35.8	35.1	34.4	34.0	33.3	32.5	1.2	3.1	5.3	9.7	14.1	16.6	20.9	26.0	
		-25	25.1	45.1	44.8	44.5	43.8	43.1	42.7	42.0	41.2	1.5	3.8	6.5	11.9	17.3	20.4	25.8	32.0	
		-31.5	32.3	58.1	57.8	57.4	56.7	56.0	55.6	54.9	54.1	1.9	4.9	8.4	15.3	22.2	26.2	33.1	41.0	
	QX5H	-40	39.2	70.5	70.0	69.4	68.3	67.1	66.5	65.3	64.0	2.3	5.9	10.1	18.5	26.8	31.6	40.0	49.6	
		-50	50.5	90.8	90.3	89.8	88.6	87.5	86.8	85.7	84.4	3.0	7.6	13.0	23.7	34.4	40.6	51.3	63.6	
		-63	63.5	114	114	113	112	111	110	109	108	3.8	9.5	16.3	29.7	43.1	50.8	64.3	79.6	
	QX6H	-80	80.1	144	143	142	140	137	136	134	131	4.7	12.0	20.4	37.3	54.2	63.9	80.7	100	
		-100	100.9	181	180	179	177	175	173	171	168	6.0	15.1	25.6	46.8	68.0	80.1	101	126	
		-125	124.6	224	223	222	220	217	216	214	211	7.4	18.5	31.6	57.6	83.7	98.6	125	154	

\* For models QX2H-5, -6.3 and -8, the maximum pressure with rotational speeds of 1000 1/min and 1200 1/min varies depending on the operating conditions. Please contact your local BIBUS representative.

# SINGLE PUMPS I

## SINGLE PUMPS: DIMENSIONS OF MANUFACTURED SIZES 2, 3

QX31

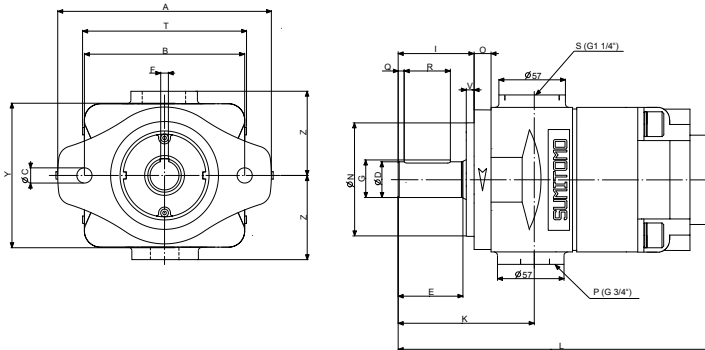

QX22, QX32

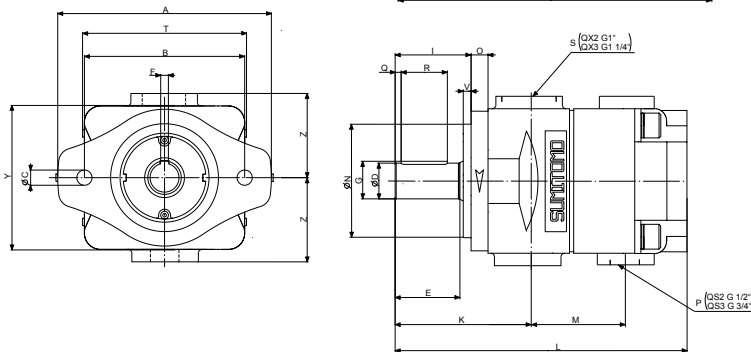

QX23, QX33, QX2H, QX3H

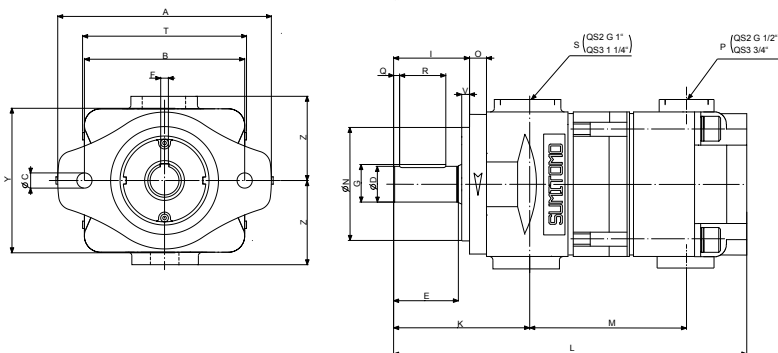

Size		QX2x-		QX3x-		
Model		QX22-	QX23- QX2H-	QX31-	QX32-	QX33- QX3H
Base model		QF-2		QF-3		
Flange design	Screwed	Suction connect. S		QGF-08		
		Pressure connect. P		QGF-04		
Pump	A	118		132		
	B	86		106		
	C	9		11		
	I	45		50		
	K	82.5		94		
	L	165.5	200.5	213.5	199.5	244.5
	M	55	90		69.5	114.5
	N	63.0 +0/-0.05		82.55 +0/-0.05		
	O	11.5		11.5		
	T	100		107		
	V	6		6		
	Y	80		100		
Z	50		60			
Shaft	D	20 +0.009/-0.004		25 +0.009/-0.004		
	E	36		42		
	F	6 +0/-0.03		8 +0/-0.036		
	G	22.4		28.1		
	Q	4		3		
	R	28		36		
Mass in kg		5.0	6.5	10.0	9.5	12.5

Pressure connection for QX2x and QX3x models are provided as screwed connection (G).  
The internal diameters of the threaded joint are always one size smaller than the corresponding bore holes.

**SINGLE PUMPS: DIMENSIONS OF MANUFACTURED SIZES 4, 5, 6**

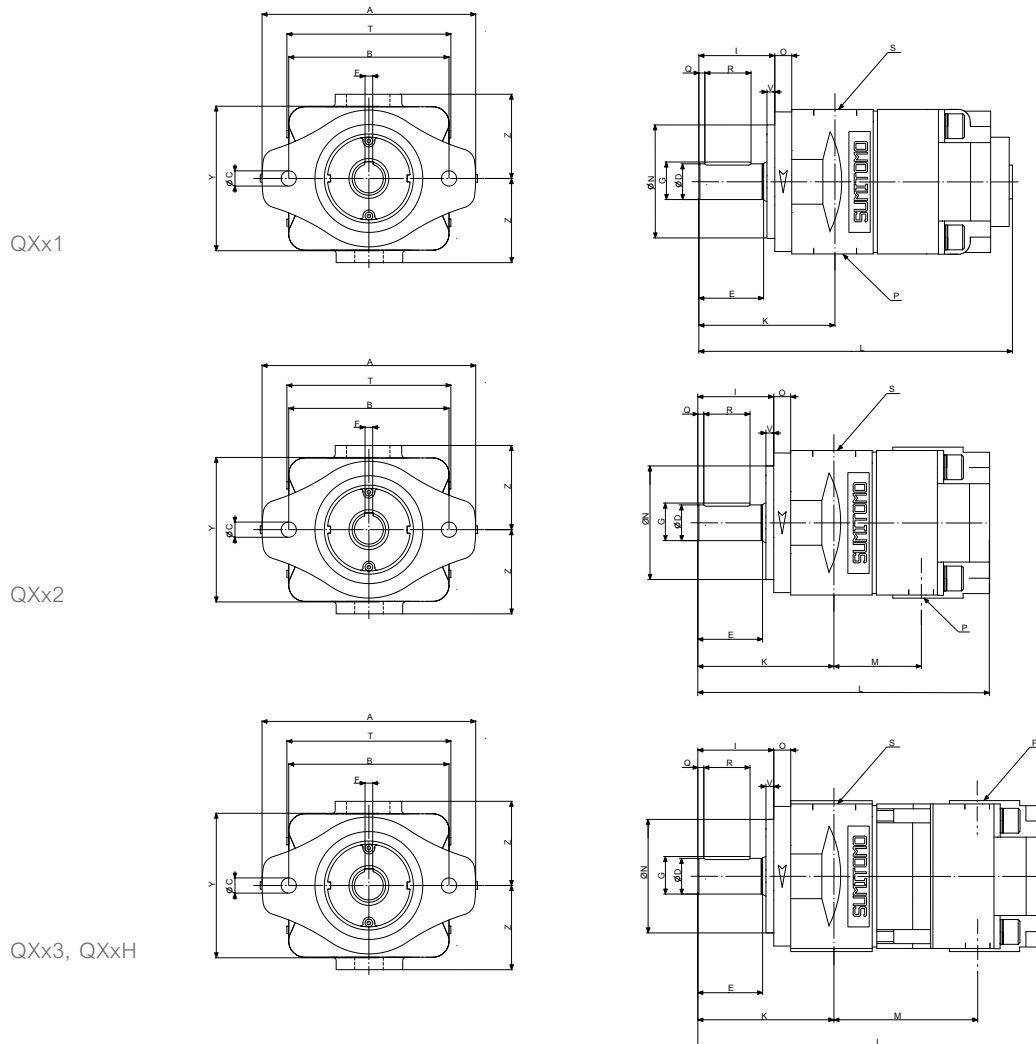

Size		QX4x-			QX5x-			QX6x-		
Model		QX41-	QX42-	QX43- QX4H-	QX51-	QX52-	QX53- QX5H-	QX61-	QX62-	QX63- QX6H-
Base model		QF-4			QF-5			QF-6		
Flange design	Screwed	Suction connect. S QGT-12 (1 1/2")			QGT-16 (2")			QGT-20 (2 1/2")		
	Welded	Suction connect. S QGW-12 (1 1/2")			QGW-16 (2")			QGW-20 (2 1/2")		
Pump	Pressure connect. P	QGT-08 (1")			QGT-10 (1 1/4")			QGT-12 (1 1/2")		
	Suction connect. S	QGW-08 (1")			QGW-10 (1 1/4")			QGW-12 (1 1/2")		
	A	170			212			267		
	B	146			181			229		
	C	14			18			23		
	I	68			92			92		
	K	120.5			152.5			166		
	L	269.5	247.5	303.5	334	305.5	375.5	379.5	345	435
	M		87	143		102	172		151	209
	N	101.6 +0/-0.05			127 +0/-0.05			152.4 +0/-0.05		
	O	13.5			15.5			20		
	T	133.4			163			200		
V	7			7			7			
Z	62.5			78			97.5			
Shaft	D	32 +0.011/-0.005			40 +0.011/-0.005			50 +0/-0.005		
	E	58			82			82		
	F	10 +0/-0.036			12 +0/-0.043			14 +0/-0.043		
	G	35			43			53.5		
	Q	4			6			6		
	R	50			70			70		
Mass in kg		18.0	17.0	22.0	33.0	31.0	40.0	64.0	60.0	76.0

Pressure connection according to the SAE J-518 standard. The welded flanges are one size smaller than the corresponding bore holes.

# SINGLE PUMPS I

## FLANGE: MODEL DESCRIPTIONS

QG	XX	XX	XX	XX
Basic model	Installation type	Size	Options	Design
Base design	T: screwed flange W: welded flange F: straight screw-in threaded joint	4-28	Without symbol: singel pump V: use of Viton seals for phosphoric ester W: special design; is only used for the suction side of the QX2x2x double pump	A

Note 1: Each flange kit contains a flange + O-ring + 4 installation bolts.

Each "straight screw-in threaded joint kit" consists of the actual straight screw-in threaded joint and a soft seal.

Note 2: With respect to the entire opening diameter of a welded flange, the F-dimensions are one size smaller.

## FLANGE: EXTERIOR DIMENSIONS

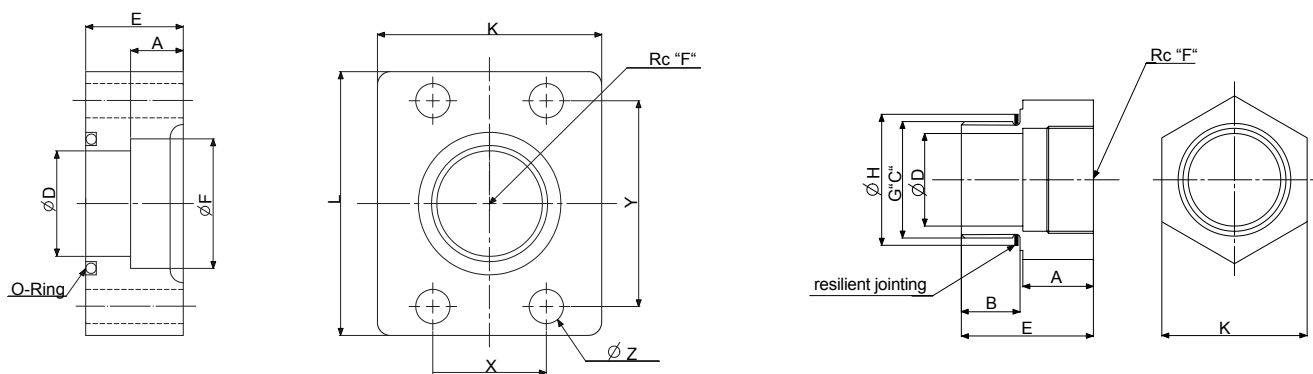

Flange type	Rated diameter	A		B	C <sub>1</sub> G <sub>2</sub>	D		E	F		H	K	L	X	Y	Z	Soft seal	O-ring JISB-2401	Screw size	Mass (kg)
		Screwed flange	Welded flange			Screwed flange	Welded flange		Screwed flange	Welded flange										
<b>Straight screw-in threaded joint</b>																				
QGF-04	1/2"	14		14	1/2"	12		33	3/8"		29	27					KP-C-04			0.2
QGF-06	3/4"	19		16	3/4"	16		38	1/2"		34.5	35					KP-C-05			0.2
QGF-08	1"	20		18	1"	20		41	3/4"		41.5	41					KP-C-06			0.4
QGF-10	1 1/4"	24		20	1 1/4"	28		46	1"		60.5	50					KP-C-07			0.6
<b>Flange</b>																				
QGx-08-A	1"	23.2	14			25	20	31	1"	27.7		50	70	26	52	11		1BP34	M10X50-10.9	0.7
QGx-10-A	1 1/4"	25.5	16			32	25	31	1 1/4"	34.5		65	79	30	59	11		1BP42	M10X50-10.9	1.1
QGx-10W-A	1 1/4"	25.5	16			32	25	31	1 1/4"	34.5		65	79	30	59	11		1BP42	M10X45-10.9	1.1
QGx-12-A	1 1/2"	25.5	18			38	32	31	1 1/2"	43.2		75	94	36	70	13		1BP50	M12X50-10.9	1.4
QGx-16-A	2"	29.8	20			50	40	37	2"	49.1		85	100	43	78	13		1BG60	M12X50-10.9	1.9
QGx-20-A	2 1/2"	33.5	22			63	50	37	2 1/2"	61.1		100	110	51	89	13		1BG70	M12X50-10.9	2.2
QGx-24-A	3"	36.8	24			75	64	44	3"	77.1		120	135	62	106.5	18		1BG80	M16X65-10.9	4.0
QGx-28-A	3 1/2"	38.4	26			89	76	44	3 1/2"	90.1		135	150	70	120.5	18		1BG95	M16X65-10.9	4.8

**BASE: MODEL DESCRIPTIONS**

QF	XX	XX	XX
Basic model	Size	Options	Design
Base design	Same as pump size	Without symbol: single pump D: double pump	Without symbol: type 2-4D A: type 5-6 only

**BASE: EXTERIOR DIMENSIONS**

QF-2, 3, 4

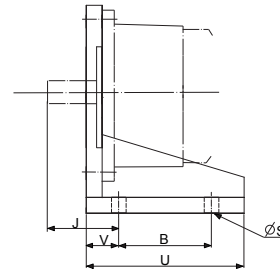
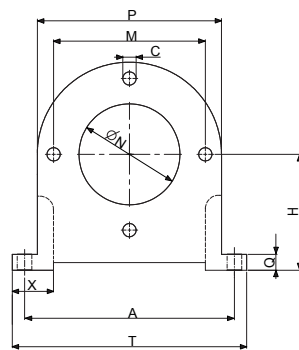
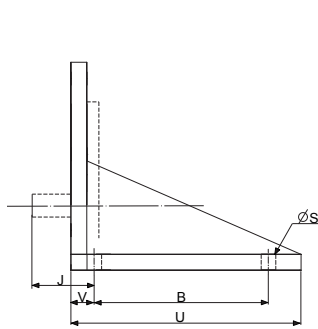

QF-5-A, 6-A

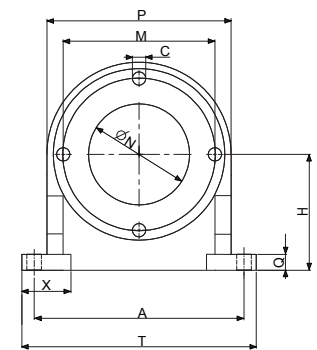

Model	A	B	C	H	J	N	M	P	Q	
									Single p.	Double p.
QF-2	158	89	M8	85	51	63.0	100	135	12	
QF-3	173	89	M10	95	66	82.55	106	150	12	
QF-4 (4D)	221	114	M12	108	65	101.6	146	194	15	24
QF-5-A	263	127	M16	145	116	127.0	181	230	22	
QF-6-A	317	140	M20	175	111	152.4	229	278	24	
Model	S	T	U		V		X	Y	Weight	
			Single p.	Double p.	Single p.	Double p.			Single p.	Double p.
QF-2	10	184	130		20		51.5		3.2	
QF-3	10	200	134		30		52		3.4	
QF-4 (4D)	12	246	140	154	13	27	58		5.4	9.2
QF-5-A	18	301	193		50		77.5		14.7	
QF-6-A	22	361	214		49		99.5		23.6	

# SINGLE PUMPS I

## SINGLE PUMPS: SECTIONAL DRAWINGS

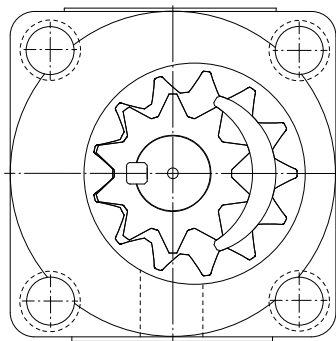
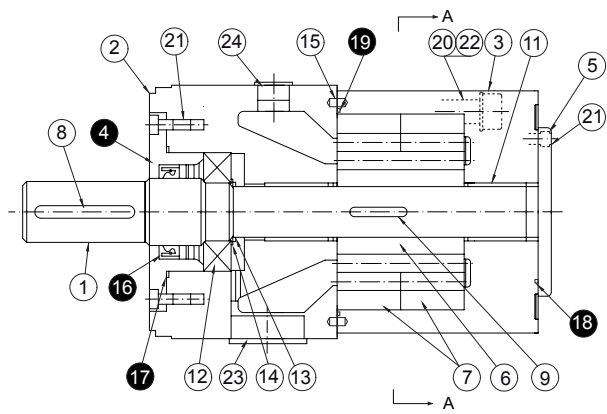
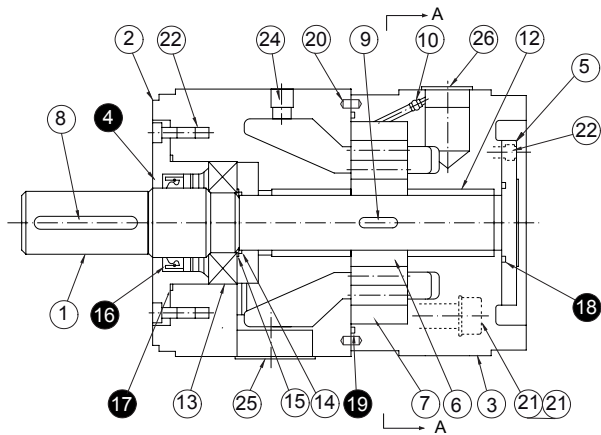

sectional view A-A

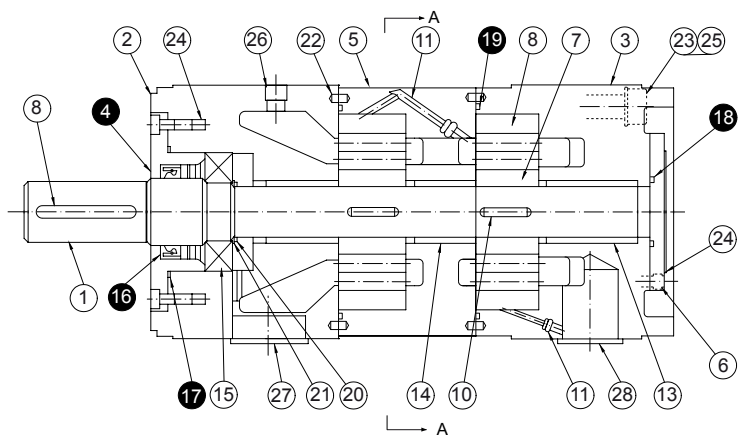

No.	Assembly		Pressure range		Model no.				
			Low pressure Medium pressure	High pressure Extreme pressure	QX2x	QX3x	QX4x	QX5x	QX6x
4, 16, 17	Housing- sealing set	Standard	1	1	09-1001-2	09-1001-3	09-1001-4	09-1001-5	09-1001-6
		High pressure			09-1001-2H	09-1001-3H	09-1001-4H	09-1001-5H	09-1001-6H
		Phosphoric ester system			09-1001-2V	09-1001-3V	09-1001-4V	09-1001-5V	09-1001-6V
		Water-glycol system			09-1001-2W	09-1001-3W	09-1001-4W	09-1001-5W	09-1001-6W
18	O-ring	Standard	1	1	AS568-121 (NBR)	AS568-124 (NBR)	AS568-129 (NBR)	AS568-225 (NBR)	AS568-229 (NBR)
		Phosphoric ester system			AS568-121 (Viton)	AS568-124 (Viton)	AS568-129 (Viton)	AS568-225 (Viton)	AS568-229 (Viton)
19	O-ring	Standard	1	2	09-1014 (NBR)	AS568-041 (NBR)	AS568-044 (NBR)	AS568-048 (NBR)	AS568-163 (NBR)
		Phosphoric ester system			09-1014 (Viton)	AS568-041 (Viton)	AS568-044 (Viton)	AS568-048 (Viton)	AS568-163 (Viton)

# Programme Double Internal Gear Pumps QX

## DOUBLE PUMPS: COMBINATION TABLE

PUMP I (high capacity, drive end)		PUMP II (low capacity, drive through end)																							
		Theoretical capacity in cm <sup>3</sup> /rev		4/5/6.3/8			10/12.5/16			20/25/31.5			40/50/63			80/100/125			160	200	250				
		Max. pressure in MPa		20.6	24.5		20.6		24.5		12.3	20.6		24.5		12.3		20.6		24.5		12.3			
Pump size		22-x	23-x		32-x		33-x		31-x	42-x		43-x		41-x		52-x		53-x		51-x	62-x		63-x		61-x
4/5/6.3/8	20.6	22-x	BB																						
	24.5	23-x																							
10/12.5/16	12.3																								
	20.6	32-x	BB	BC	BB																				
	24.5	33-x																							
20/25/31.5	12.3	31-x																							
	20.6	42-x	BB	BC	BB		BC	BB																	
	24.5	43-x	CC																						
40/50/63	12.3	41-x	AB	AC	AB		AC																		
	20.6	52-x	BC		BC		BB		BC	BB															
	24.5	53-x	CC																						
80/100/125	12.3	51-x	AC		AB		AC	AB		AC															
	20.6	62-x	BB		BC	BB		BB																	
	24.5	63-x	CC																						
160	200	250	12.3	61-x	AB		AC	AB		AC															

■ Standard combination ■ Special combination (manufactured by request)

Note 1: Standard pumps have a clockwise sense of rotation. View from the motor to the shaft end, rotating clockwise.

Note 2: The designations AA, BC, etc. in the table are group classifications corresponding to the differences of the exterior shape of the double pump or the relative position of the connections.

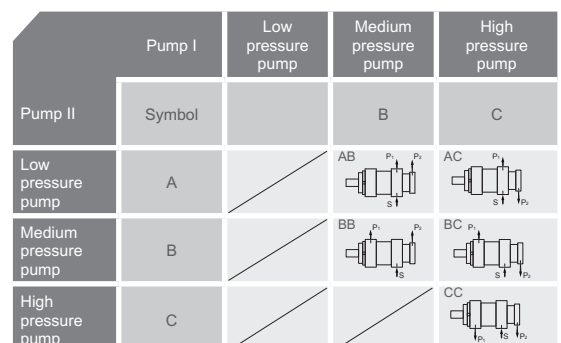

# DOUBLE PUMPS I

## DOUBLE PUMPS: PRODUCT OVERVIEW

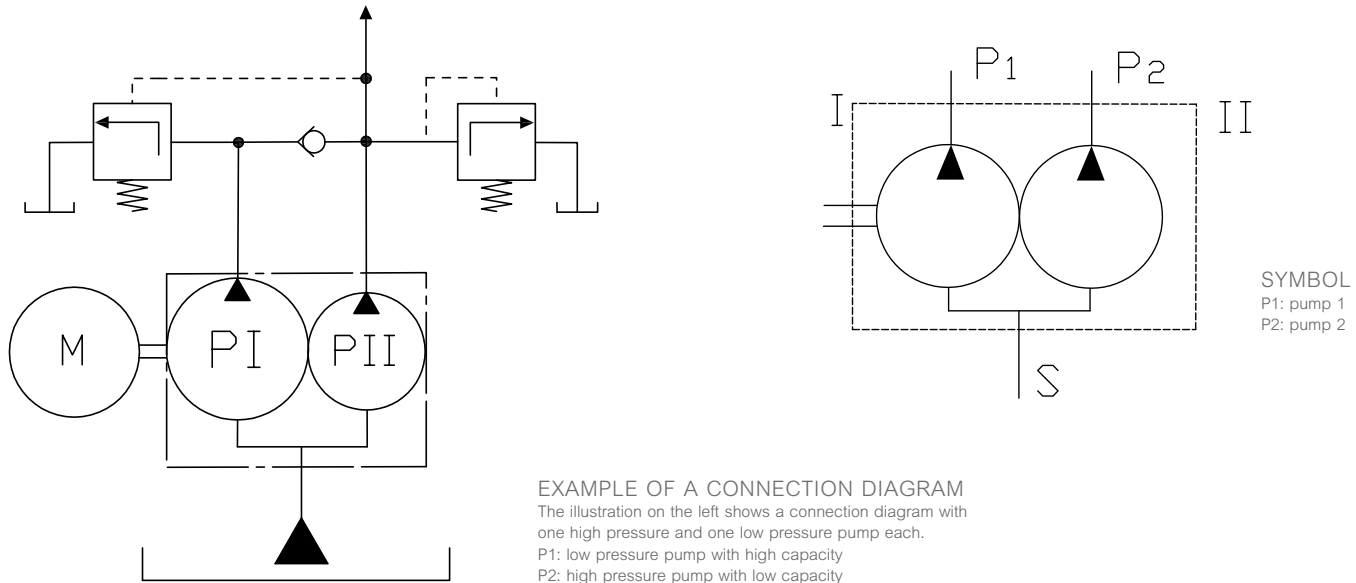

QX	XX	XX	XX	XX	XX	XX	XX	S	A	
Basic model	Manufactured size pump 1	Pressure range pump 1	Manufactured size pump 2	Pressure range pump 2	Theor. capacity pump 1	Theor. capacity pump 2	Options	Specifications	Draft no.	
Gear pump for high pressures at low noise levels	2	1: low pressure	2	1: low pressure	See pump overview table	See pump overview table	Suction pressure	Entry in case of special specifications only	00: without symbol 0x: compatible x: not compatible	
	3		3				3: medium pressure			Without symbol: -0.03 to 0.03 MPa (standard) H: 0 to 0.2 MPa (high pressure lip seal)
	4	2: medium pressure	4	2: medium pressure			Sealing material			
	5	3: high pressure	5	3: high pressure			Without symbol: NBR V: use of Viton seals for phosphoric ester W: water-glycol base (change in the pump only)			
	6		6							
	See pump overview tables (pages 25–26) See double pump combination table (Page 23)									

The standard sense of rotation of double pumps is clockwise. Pumps with a counter-clockwise sense of rotation are available by request. Please contact the BIBUS representative in your country.

## DOUBLE PUMPS: ORDER EXAMPLES

EXAMPLE 1

**QF-04 D**

Model  
 Manufactured size "4"  
 For double pump

EXAMPLE 2

**QX-5 1 4 3-80-20 H-A**

Model  
 Pump 1: manufactured size "5"  
 Pump 1: low pressure  
 Pump 2: manufactured size "4"  
 Pump 2: high pressure  
 Series  
 High pressure lip seal  
 Connections P2 of pump PII 180° turned  
 Theor. capacity pump 2: 20 cm<sup>3</sup>/rev  
 Theor. capacity pump 1: 80 cm<sup>3</sup>/rev



DOUBLE PUMPS: DIMENSIONS

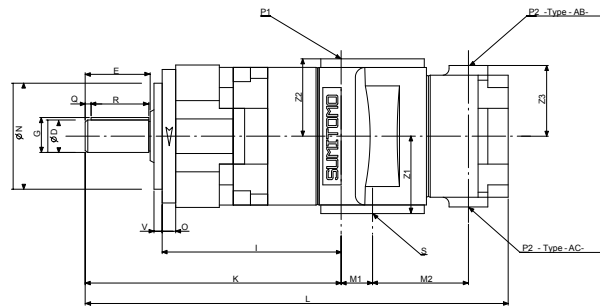
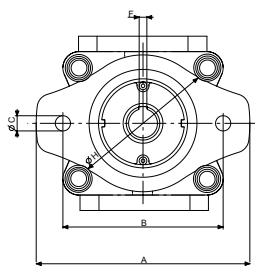

AB PUMP COMBINATION

The two drawings illustrate an AB and AC pump combination

Model	A	B	C	D	E	F	G	H	I	K	L	M1	M2	M3	N	O	Q	R	V
QX4122-x-x	170	146	14	32 <sup>+0.011</sup> <sub>-0.005</sub>	58	10 <sup>0</sup> <sub>-0.036</sub>	35	115	180.5	248.5	380.5	20	84	0	101.6 <sup>0</sup> <sub>-0.05</sub>	13	4	50	7
QX4132-x-x											396.5	20	92						
QX5132-x-x	212	181	18	40 <sup>+0.011</sup> <sub>-0.005</sub>	82	12 <sup>0</sup> <sub>-0.043</sub>	43	145	218.5	310.5	468.5	22.5	99.5	15	127 <sup>0</sup> <sub>-0.05</sub>	14.5	6	70	7
QX5142-x-x											483.5	22.5	110.5						
QX6142-x-x	267	229	23	50 <sup>+0.011</sup> <sub>-0.005</sub>	82	14 <sup>0</sup> <sub>-0.043</sub>	53.5	184	260	352	542	27	123	26	152.4 <sup>0</sup> <sub>-0.05</sub>	18.5	6	70	7
QX6152-x-x											572	32	137						

Model	Z1	Z2	Z3	Suction side		Pressure side		Base design
				S	P1	P2		
QX4122-x-x	62.5	62.5	50	QGx-16	QGx-08	QGF-04	QF-4D	
QX4132-x-x			60			QGF-06		
QX5132-x-x	78	78	60	QGx-20	QGx-10	QGF-06	QF-5	
QX5142-x-x			62.5			QGx-08		
QX6142-x-x	97.5	97.5	62.5	QGx-24	QGx-12	QGx-08	QF-6	
QX6152-x-x			78	QGx-28		QGx-10		

AC PUMP COMBINATION

Model	A	B	C	D	E	F	G	H	I	K	L	M1	M2	M3	N	O	Q	R	V
QX4123-x-x	170	146	14	32 <sup>+0.011</sup> <sub>-0.005</sub>	58	10 <sup>0</sup> <sub>-0.036</sub>	35	115	180.5	248.5	415.5	20	119	0	101.6 <sup>0</sup> <sub>-0.05</sub>	13	4	50	7
QX4133-x-x											441.5	20	137						
QX5123-x-x	212	181	18	40 <sup>+0.011</sup> <sub>-0.005</sub>	82	12 <sup>0</sup> <sub>-0.043</sub>	43	145	218.5	310.5	487.5	22.5	126.5	15	127 <sup>0</sup> <sub>-0.05</sub>	14.5	6	70	7
QX5133-x-x											513.5	22.5	144.5						
QX5143-x-x											539.5	22.5	166.5						
QX6143-x-x	267	229	23	50 <sup>+0.011</sup> <sub>-0.005</sub>	82	14 <sup>0</sup> <sub>-0.043</sub>	53.5	184	260	352	598	27	179	26	152.4 <sup>0</sup> <sub>-0.05</sub>	18.5	6	70	7
QX6153-x-x											624	32	207						

Model	Z1	Z2	Z3	Suction side		Pressure side		Base design
				S	P1	P2		
QX4123-x-x	62.5	62.5	50	QGx-16	QGx-08	QGF-04	QF-4D	
QX4133-x-x			60			QGF-06		
QX5123-x-x	78	78	50	QGx-20	QGx-10	QGF-04	QF-5	
QX5133-x-x			60			QGF-06		
QX5143-x-x			62.5			QGx-08		
QX6143-x-x	97.5	97.5	62.5	QGx-24	QGx-12	QGx-08	QF-6	
QX6153-x-x			78	QGx-28		QGx-10		

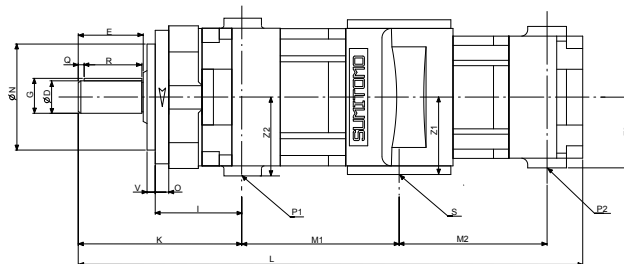
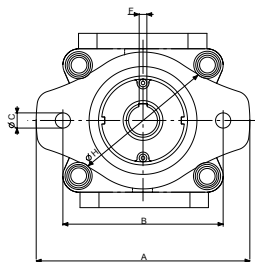

CC PUMP COMBINATION

The two drawings illustrate a CC pump combination

Model	A	B	C	D	E	F	G	H	I	K	L	M1	M2	N	O	Q	R	V
QX4333-x-x	170	146	14	32 <sup>+0.011</sup> <sub>-0.005</sub>	58	10 <sup>0</sup> <sub>-0.036</sub>	35	115	71.5	139.5	471.5	159	137	101.6 <sup>0</sup> <sub>-0.05</sub>	13	4	50	7
QX5343-x-x	212	181	18	40 <sup>+0.011</sup> <sub>-0.005</sub>	82	12 <sup>0</sup> <sub>-0.043</sub>	43	145	89.5	181.5	577.5	189.5	166.5	127 <sup>0</sup> <sub>-0.05</sub>	14.5	6	70	7
QX6363-x-x	267	229	23	50 <sup>+0.011</sup> <sub>-0.005</sub>	82	14 <sup>0</sup> <sub>-0.043</sub>	53.5	184	103	195	733	239	239	152.4 <sup>0</sup> <sub>-0.05</sub>	18.5	6	70	7

Model	Z1	Z2	Z3	Suction side		Pressure side		Base design
				S	P1	P2		
QX4333-x-x	62.5	62.5	60	QGx-16	QGx-08	QGF-06	QF-4D	
QX5343-x-x	78	78	62.5	QGx-20	QGx-10	QGx-08	QF-5	
QX6363-x-x	97.5	97.5	97.5	QGx-28	QGx-12	QGx-12	QF-6	

# DOUBLE PUMPS I

## DOUBLE PUMPS: DIMENSIONS

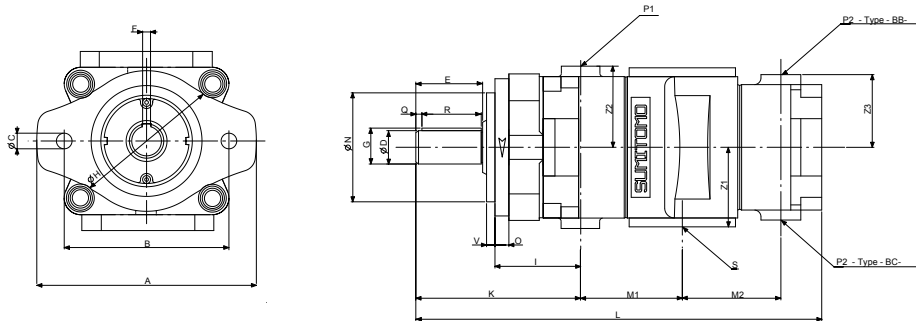

The two drawings illustrate a BB and BC pump combination

### BB PUMP COMBINATION

Model	A	B	C	D	E	F	G	H	I	K	L	M1	M2	N	O	Q	R	V
QX2222-x-x	118	100	9	20 <sup>+0.009</sup> <sub>-0.004</sub>	36	6 <sup>-0</sup> <sub>-0.03</sub>	22.4	76	55.5	100.5	262.5	67	67	63 <sup>-0</sup> <sub>-0.05</sub>	11	4	28	6
QX3222-x-x	132	106	12	25 <sup>+0.009</sup> <sub>-0.004</sub>	42	8 <sup>-0</sup> <sub>-0.036</sub>	28.1	95	63.5	113.5	307.5	87	79	82.55 <sup>-0</sup> <sub>-0.05</sub>	11	3	36	6
QX3232-x-x											323.5	87	87					
QX4222-x-x											354.5	103	84					
QX4232-x-x	170	146	14	32 <sup>+0.011</sup> <sub>-0.005</sub>	58	10 <sup>-0</sup> <sub>-0.036</sub>	35	115	71.5	139.5	370.5	103	92	101.6 <sup>-0</sup> <sub>-0.05</sub>	13	4	50	7
QX4242-x-x											400.5	110.5	110.5					
QX5242-x-x	212	181	18	40 <sup>+0.011</sup> <sub>-0.005</sub>	82	12 <sup>-0</sup> <sub>-0.043</sub>	43	145	89.5	181.5	451.5	119.5	110.5	127 <sup>-0</sup> <sub>-0.05</sub>	14.5	6	70	7
QX5252-x-x											486.5	127	127					
QX6252-x-x	267	229	23	50 <sup>+0.011</sup> <sub>-0.005</sub>	82	14 <sup>-0</sup> <sub>-0.043</sub>	53.5	184	103	195	532	149	137	152.4 <sup>-0</sup> <sub>-0.05</sub>	18.5	6	70	7
QX6262-x-x											553	149	149					

Model	Z1	Z2	Z3	Suction side	Pressure side		Base design
				S	P1	P2	
QX2222-x-x	50	50	50	QGx-10W*	QGF-04	QGF-04	QF-2
QX3222-x-x	60	60	50	QGx-12	QGF-06	QGF-04	QF-3
QX3232-x-x			60			QGF-06	
QX4222-x-x	62.5	62.5	50	QGx-16	QGF-06	QGF-04	QF-4D
QX4232-x-x			60			QGF-06	
QX4242-x-x			62.5			QGx-08	
QX5242-x-x	78	78	62.5	QGx-20	QGF-06	QGF-06	QF-5
QX5252-x-x			78			QGF-06	
QX6252-x-x	97.5	97.5	78	QGx-28	QGF-06	QGF-06	QF-6
QX6262-x-x			97.5			QGF-06	

\* The flange of QGx-10W is a QX2x2x special inlet flange.

### BC PUMP COMBINATION

Model	A	B	C	D	E	F	G	H	I	K	L	M1	M2	N	O	Q	R	V
QX3223-x-x	132	106	12	25 <sup>+0.009</sup> <sub>-0.004</sub>	42	8 <sup>-0</sup> <sub>-0.036</sub>	28.1	95	63.5	113.5	342.5	87	114	82.55 <sup>-0</sup> <sub>-0.05</sub>	11	3	36	6
QX4223-x-x	170	146	14	32 <sup>+0.011</sup> <sub>-0.005</sub>	58	10 <sup>-0</sup> <sub>-0.036</sub>	35	115	71.5	139.5	389.5	103	119	101.6 <sup>-0</sup> <sub>-0.05</sub>	13	4	50	7
QX4233-x-x											415.5	103	137					
QX5223-x-x											455.5	119.5	126.5					
QX5233-x-x	212	181	18	40 <sup>+0.011</sup> <sub>-0.005</sub>	82	12 <sup>-0</sup> <sub>-0.043</sub>	43	145	89.5	181.5	481.5	119.5	144.5	127 <sup>-0</sup> <sub>-0.05</sub>	14.5	6	70	7
QX5243-x-x											507.5	119.5	166.5					
QX6253-x-x	267	229	23	50 <sup>+0.011</sup> <sub>-0.005</sub>	82	14 <sup>-0</sup> <sub>-0.043</sub>	53.5	184	103	195	602	149	207	152.4 <sup>-0</sup> <sub>-0.05</sub>	18.5	6	70	7

Model	Z1	Z2	Z3	Suction side	Pressure side		Base design
				S	P1	P2	
QX3223-x-x	60	60	50	QGx-12	QGF-06	QGF-04	QF-3
QX4223-x-x	62.5	62.5	50	QGx-16	QGF-06	QGF-04	QF-4D
QX4233-x-x			60			QGF-06	
QX5223-x-x	78	78	50	QGx-20	QGF-06	QGF-04	QF-5
QX5233-x-x			60			QGF-06	
QX5243-x-x			62.5			QGx-08	
QX6253-x-x	97.5	97.5	78	QGx-28	QGF-06	QGF-06	QF-6

## Operation Hints

### 1. Hydraulic Fluid

Use hydraulic fluid with the viscosity of ISO VG46 ~ 68 (With viscosity index of more than 70 kgf/cm<sup>2</sup> anti-wear hydraulic fluid of ISO VG46 ~ 68 is recommendable.)

Consult the manufacturer in case no inflammable fluid (phosphate-ester, water-glycol, fatty ester, water in oil emulsion, etc) is used.

Use clean fluid without foreign bodies or water. Whitened fluid indicates aeration and brown fluid deterioration.

### 2. Viscosity and Temperature of Fluid

Viscosity: 20 ~ 500 cSt.

Temperature: 0° C ~ 60° C

### 3. Suction Pressure

Suction pressure must be within -0.3 ~ +0.3 kgf/cm<sup>2</sup>

(Specify high suction pressure shaft seal if pump is used at suction pressure higher than + 0.3 kgf/cm<sup>2</sup>)

### 4. Filtration

Fit a filter of 150 mesh or above in suction line. A 25 μm in-line filter in delivery line or a magnet filter will extend pump life.

### 5. Installation and Alignment

Mount pump on a base with sufficient rigidity.

Pump must be so mounted that the suction port may be on either side or upper position.

Eccentricity between shafts of pump and motor must be less than 0.05 mm by using flexible coupling such as chain coupling. Avoid radial force on pump shaft.

Coupling must go in and out on pump shaft smoothly.

### 6. Piping

Use piping flanges.

Piping size of suction line must be chosen to allow fluid flow of less than 1.5 m/sec and suction pressure less than -0,3 kgf/cm<sup>2</sup> piping must be as short as possible.

Avoid push-or pull-force when using steel pipe.

### 7. Initial Start-Up

For good lubrication between moving and stationary elements pour fluid into the pump before use.

To purge air in pump body, be sure to operate pump by an inching Start (on and off) at unload.

### 8. Rotating Direction

Clockwise (seen from shaft end) is Standard. Counter clockwise optional.



Check rotation direction by a moment start-up of motor.

### 9. Maximum Pressure

Operation at maximum pressure must not exceed 1/3 of one cycle and 20 seconds.

### 10. Consult the manufacturer if disassembly is required.



-  Countries with a BIBUS branch office
-  Germany: registered office of SAUER BIBUS including competence centre for high-performance internal gear pumps

© 2010, SAUER BIBUS. All rights reserved.  
SAUER BIBUS is unable to accept any liability for errors in catalogues, brochures or other printed media and reserves the right to alter products and product offers without prior notice. This also applies to existing products, provided that product changes do not affect the agreed product characteristics. Please request a binding installation drawing prior to fixed calculation. All trademarks are the property of the registered proprietor. SAUER BIBUS and the SAUER BIBUS logo are registered trademarks of the BIBUS group.

SUM 12/08-300101e

**SAUER BIBUS GmbH**  
Lise-Meitner-Ring 13  
DE-89231 Neu-Ulm  
Phone: +49 731 1896-0  
Fax: +49 731 1896-199  
E-Mail: [info@sauerbibus.de](mailto:info@sauerbibus.de)  
Internet: [www.sauerbibus.de](http://www.sauerbibus.de)

**SAUER BIBUS**  
**//// SUPPORTING YOUR SUCCESS**